



CONSTRUCTION SOLUTIONS, INC
ENGINEERING - TESTING - PROJECT MANAGEMENT
www.constructionsolutions.cc

BEACHCOMBER I CONDOMINIUM



REPAIRS & RENOVATIONS PROJECT MANUAL March 1, 2018

**961687 GATEWAY BLVD, SUITE 101B
AMELIA ISLAND, FLORIDA 32034**

**151 SAWGRASS CORNERS DRIVE, SUITE 206
PONTE VEDRA BEACH, FLORIDA 32082**

P 904-261-8703 F 877-808-1839

DOCUMENT 001116 - INVITATION TO BID

1.1 PROJECT INFORMATION

- A. Notice to Bidders: Qualified bidders are invited to submit bids for Project as described in this Document according to the Instructions to Bidders.
- B. Project Identification: Beachcomber I Condominium Repairs & Renovations.
- C. Project Location: 413 1st Street South Jacksonville Beach, Florida 32250
- D. Owner: Beachcomber I Condominium Association, Inc.
- E. Engineer: Construction Solutions, Inc., 961687 Gateway Blvd., Suite 101B, Amelia Island, Florida 32034. Contact phone number is 904-261-8703.
- F. Owner's Representative: Construction Solutions, Inc.
- G. Project Description: See Specification Section 011000.
- H. Renovation Contract: Bids will be received for the following Work:
 - 1. General Contract (all trades).

1.2 BID SUBMITTAL AND OPENING

- A. Owner will receive sealed bids until the bid time and date at the location indicated below. Owner will consider bids prepared in compliance with the Instructions to Bidders issued by Owner, and delivered as follows:
 - 1. Bid Date: Thursday, March 29, 2018
 - 2. Bid Time: 5:00 p.m., local time.
 - 3. Location: Construction Solutions, Inc., 961687 Gateway Blvd., Suite 101B, Amelia Island, Florida 32034.
- B. Bids will be thereafter privately opened.
- C. Owner not obligated to make any award to contractor.

1.3 PRE-BID CONFERENCE

- A. A mandatory pre-bid conference for all bidders will be held onsite. Prospective bidders are **required** to attend. See Section 002513.

1.4 DOCUMENTS

- A. Procurement and Contracting Documents: Obtain access by contacting Engineer of Record. Access will be provided to prime bidders by invitation only.
- B. TIME OF COMPLETION _____.
- C. Bidders shall begin the Work on receipt of the Notice to Proceed and shall complete the Work within the Contract Time.

1.5 BIDDER'S QUALIFICATIONS

- A. Bidders must be pre-qualified by Owner.
- B. Bidders must be properly licensed under the laws governing their respective trades and be able to obtain insurance and bonds required for the Work. **A Performance Bond, a separate Labor and Material Payment Bond, and Insurance in a form acceptable to Owner may be required of the successful Bidder. Please provide an attachment along with submission of bid with applicable bonding rates.**

END OF DOCUMENT 001116

DOCUMENT 001153 - REQUEST FOR QUALIFICATIONS

1.1 PURPOSE, LAWS, AND REGULATIONS

- A. The purpose of the Pre-Qualifications Procedure described in this Document is to provide Owner with a mechanism to evaluate and determine whether Prospective Bidders are qualified to participate in the construction of Project. Evaluation will be limited to that office of the Prospective Bidder that is proposed to perform the Work.
- B. Prospective Bidders are required to comply with these Requirements for Pre-Qualifications. Only those Prospective Bidders who have complied with the Requirements for Pre-Qualifications and have been determined to be qualified will be eligible to submit construction bids on Project.

1.2 DEFINITIONS

- A. Prospective Bidder: A Prospective Bidder is a person or entity who submits a Submittal of Qualifications to Owner.

1.3 PRE-QUALIFICATIONS DOCUMENTS

- A. Pre-Qualifications Documents: Consist of the Advertisement for Pre-Qualifications of Bidders; this Request for Qualifications document; AIA Document A305, "Contractor's Qualification Statement"; and additional documents issued by Owner.
- B. Obtaining Pre-Qualifications Documents: Prospective Bidders may obtain complete sets of the Pre-Qualifications Documents from the issuing office designated in the Advertisement for Pre-Qualifications of Bidders. Prospective Bidders shall use complete sets of Pre-Qualifications Documents in preparing their submittal. Owner assumes no responsibility for errors or misinterpretations resulting from the use of incomplete sets of Pre-Qualifications Documents.
- C. Interpretation or Correction of Pre-Qualifications Documents: If the Prospective Bidder is in doubt as to the interpretation of any part of the Pre-Qualifications Documents, or finds discrepancies in or omissions from any part of the Pre-Qualifications Documents, it must submit a written Request for Interpretation thereof no later than **(7)** days prior to acceptance of Submittals of Qualifications. Address all communications to Owner.

1.4 PRE-QUALIFICATIONS PROCEDURES

- A. Form of Pre-Qualifications Submittal:
 - 1. Submittals of Pre-Qualifications must be submitted in duplicate on AIA Document A305, "Contractor's Qualification Statement," properly executed and with all items filled out in ink or typed, and all additional data, attachments, and forms provided. Do not change or

add words to the Qualification Statement or forms. All signatures must be original (and sealed if a corporation) and must be notarized and sealed by a Notary Public.

- B. Modification to Requirements for Pre-Qualifications:
1. Clarifications, alterations, or changes made by Owner to the Requirements for Pre-Qualifications shall be in writing only. Verbal information is not valid or binding.
 2. Modifications will be mailed or delivered to those Prospective Bidders having obtained Pre-Qualifications Documents from the issuing office.
- C. Submission of Pre-Qualifications Documents:
1. Each Submittal of Pre-Qualifications shall be delivered to the location indicated in the Advertisement for Pre-Qualifications on or before the day and hour set for receipt of Submittals. Each Submittal of Pre-Qualifications shall be submitted in an opaque, sealed envelope marked in the lower left-hand corner as follows:
 - a. Bidder's Pre-Qualifications Statement for Beachcomber I Condominium Repairs & Renovations.
 - b. Prospective Bidder's Name.
 - c. Prospective Bidder's Address.
 - d. Contractor's License No.
 - e. Date and Time for Submittal.
 2. If not delivered in person, this envelope shall be enclosed in a second envelope for posting to the location indicated for receipt of bids. This envelope shall be addressed as follows:
 - a. Bidder's Pre-Qualifications Statement for Beachcomber I Condominium Repairs & Renovations.
 - b. Date and Time for Submittal.
 - c. Beachcomber I Condominium
 - d. 413 1st Street South
 - e. Jacksonville Beach, Florida, 32250.
 - f. Contractor's License No. (In return address).
 - g. Email is acceptable.
 3. Include a completed copy of the Pre-Qualifications Checklist attached to the cover of the Submittal.
 4. It is the sole responsibility of the Prospective Bidder to ensure that its submittal is received by the submittal date and time. No faxed or e-mail submittal or modification of a submittal will be considered. No submittal submitted after the time fixed for receiving submittals will be considered; late submittals will be returned to the Prospective Bidder unopened.
 5. Owner reserves the right to waive any informality and to request additional information from Prospective Bidders, at Owner's discretion.
- D. Attachments:
1. Prospective Bidders shall complete all required forms and attachments described in the Pre-Qualifications Documents, entering "Not Applicable" where information does not apply. Absence of any of the forms included in the Pre-Qualification Documents will be reason for possible disqualification.
- E. Status of Prospective Bidders:

1. Proprietors submitting bids shall indicate their status as proprietors.
2. Prospective Bidders submitting qualifications for partnerships shall indicate their status as partners and shall submit a certified copy of the power of attorney authorizing the executor of the submittal to bind the partnership.
3. Prospective Bidders submitting qualifications for corporations shall indicate their status as corporations and shall submit a certified copy of the board of directors' authorization for the Prospective Bidder to bind the corporation and shall affix the corporate seal on the submittal.
4. Prospective Bidders shall provide the following:
 - a. Names and addresses of proprietors, of all members of a partnership, or of the corporation's officers.
 - b. Name of jurisdiction where the partnership is registered or where the corporation is incorporated. Corporations must be licensed to do business in Project state at the time of executing the Contract.

1.5 WITHDRAWAL

- A. A Qualification Statement may be withdrawn on personal request received from the Prospective Bidder.

1.6 PRE-QUALIFICATIONS CRITERIA

- A. Prospective Bidders must demonstrate the following to the satisfaction of Owner:
 1. Proper license under the laws and regulations governing their respective trade(s).
 2. Capacity to provide Performance Bond, Labor and Material Payment Bond, and Insurance in a form acceptable to Owner in amounts adequate to bond the Work based on the scope indicated in the Advertisement for Pre-Qualifications.
 - 3.
 4. Applicable experience of firm as described in the Contractor's Qualification Statement, including the following:
 - a. Experience of Firm: The firm in its current organization shall have successfully completed minimum of **(3)** projects of similar type, quality, and scope, including a minimum of **(1)** within the last year. The firm shall have a record of project completion, credit record, record of judgment claims, arbitration proceedings, and suits pending or outstanding acceptable to Owner.
 - b. Experience of Firm Officers: The firm officers shall have personal record of project completion acceptable to Owner.
 - c. Experience of Project and Field Management Staff to Be Committed by the Prospective Bidder to Carry Out the Work: The assigned project manager and field superintendent must have successfully completed minimum of **(2)** projects of similar type, quality, and scope.
 - d. For purposes of this submittal, reference to "key individuals" as described in the Contractor's Qualification Statement shall be understood to mean the principal in charge, the project manager(s), and the project field superintendent(s) committed by the Prospective Bidder to carry out the Work of this Project. Prospective Bidder by submitting qualifications of key individuals agrees that

Owner reserves the right to approve or reject subsequent reassignment of key individuals.

- e. For purposes of this submittal, "successful completion" shall be understood to mean completion of project within project schedule and budget. Provide additional information indicating reasons why any referenced project did not meet project schedule or project budget.
- f. For purposes of this Qualification, "similar project" shall be understood to include the majority of the following project elements:
 - 1) Concrete and masonry repairs.
 - 2) Stucco/EIFS repairs.
 - 3) Metal / wood stud wall repair
 - 4) Epoxy crack injection.
 - 5) Painting and waterproofing.
 - 6) Handrail replacement.
 - 7) Stairwell replacement.
 - 8) Tile removal and installation.
 - 9) Structural Steel Repair
- 5. Adequate financial resources, including ability to secure materials and labor necessary for completion of the Work and other work in hand, within the anticipated contract times, and reflecting the anticipated retainage from progress payments.
- 6. Work-in-hand capacity, such that the Prospective Bidder demonstrates adequate work under contract to continue its business operations at least at their current level, at the same time indicating the capability to carry out Owner's proposed work.
- 7. Adequate organization to complete work of the scope anticipated, including firm management, project management, field superintendence, and field engineering and quality control.
- 8. Acceptable past performance as indicated by firm's references, including ability to meet contract time and to monitor, manage, and communicate interim scheduling requirements, to carry out required quality-control activities, to properly prepare interim and final payment requests, and to successfully complete project closeout requirements.
- 9. Acceptable documentation of firm's employee screening practices as indicating by affidavit describing background check procedures for firm's employees and requirements for same incorporated in firm's subcontracts.

Insert additional safety/ EMR qualifications below:

- 10. _____
- 11. _____
- 12. _____
- 13. _____
- 14. _____
- 15. _____
- 16. _____
- 17. _____
- 18. _____
- 19. _____
- 20. _____

- 21. _____
- 22. _____
- 23. _____
- 24. _____

- A. Consideration of qualifications may be withheld if the Qualification Statement shows any unexplained erasures, omissions, alterations of form, additions not called for, added restrictions or qualifying conditions, or other irregularities of any kind.
- B. Owner may make such investigations as it deems necessary to determine the ability of the Prospective Bidder to perform the Work, and the Prospective Bidder shall furnish to Owner all such information for this purpose as Owner may request. Owner reserves the right to withhold qualification if the evidence submitted by or investigation of such Prospective Bidder fails to satisfy Owner that such Prospective Bidder is properly qualified to carry out the obligations of the proposed Project. The determination of which bidders are prequalified is not protestable, except as allowed by law.
- C. Pre-Qualifications Submittal and data contained therein is considered privileged and confidential and will not be disclosed to any outside party except as required by law.

1.7 BONDS AND INSURANCE

- A. The Prospective Bidder shall provide as part of the Submittal of Qualifications evidence of its ability to furnish below:
 - 1. Performance Bond, a Payment Bond, and a Labor and Material Bond, each in the amount of 100 percent of the Contract Sum, with a corporate surety authorized to transact business in Project's jurisdiction.
 - 2. Satisfactory certificates of insurance in the amount and types required by statute, but not less than the following:
 - a. Workers' Compensation insurance provisions: statutory limits.
 - b. Commercial General Liability insurance provisions: at limits established by Owner in Project Contract Documents.
 - 3. Insurance certificates should name Beachcomber I Condominium and Construction Solutions, Inc. as additionally insured.

1.8 ACCEPTANCE OF QUALIFICATIONS

- A. Prospective bidders will be notified of Owner's determination, within **(14)** days from the date of submission.
- B. Evaluations will be confidential. Notifications will be publicly available information.
- C. Owner may deny Pre-Qualifications if it finds one or more of the following:
 - 1. The Prospective Bidder does not have sufficient financial capacity to perform the Work.
 - 2. The Prospective Bidder does not have the appropriate experience to perform the Work, including, but not limited to, having met the experience criteria set forth herein.

3. The Prospective Bidder or any officer, director, or owner thereof has had judgments entered against him within the past five years for the breach of contracts for governmental or nongovernmental construction work including, but not limited to, design-build or construction management contracts.
 4. The Prospective Bidder has been in substantial noncompliance with the terms and conditions of prior construction with Owner, or in documented substantial noncompliance with the terms and conditions of prior construction with another public body without good cause.
 5. The Prospective Bidder provides false, nonresponsive, misleading, or incomplete information for items required herein.
- D. The acceptance of a Prospective Bidder's qualifications will be a Notice of Pre-Qualifications, signed by a duly authorized representative of Owner; no other act by Owner or its agents shall constitute the acceptance of qualifications. The acceptance of a Prospective Bidder's qualifications by Owner does not constitute a contract or promise to award a contract to the Prospective Bidder.

1.9 PROSPECTIVE BIDDER'S CHECKLIST

- A. In an effort to assist the Prospective Bidder in properly completing all documentation required, the following checklist is provided for the Prospective Bidder's convenience. The Prospective Bidder is solely responsible for verifying compliance with Pre-Qualifications requirements.
- B. Attach this completed checklist to the outside of the Submittal envelope.
1. Reviewed the Pre-Qualifications Documents, including the Advertisement for Pre-Qualifications and Requirements for Pre-Qualifications, prior to preparing this submittal.
 2. Prepared AIA Document A305, "Contractor's Qualification Statement," as required by the document instructions and by the Requirements for Pre-Qualifications, including all attachments and data required as part of the Qualification Statement, properly notarized.
 3. Attached: Copy of applicable Contractor's license(s).
 4. Attached: Affidavit of Employee Screening.
 5. Attached: Resumes of key individuals.
 6. Attached: Other attachments as necessary to provide information required.
 7. Envelope shows name and address of the Prospective Bidder.
 8. Envelope shows the Prospective Bidder's Contractor's License No.
 9. By submitting notarized statement, the Prospective Bidder certifies that the Bidder can provide executed Performance Bond and Labor and Material Bond meeting requirements given in the Requirements for Pre-Qualifications.
 10. By submitting notarized statement, the Prospective Bidder certifies that the Bidder can provide Certificates of Insurance in the amounts indicated in the Requirements for Pre-Qualifications.

END OF DOCUMENT 001153

DOCUMENT 002113 - INSTRUCTIONS TO BIDDERS

1.1 INSTRUCTIONS TO BIDDERS

- A. AIA Document A701, "Instructions to Bidders," is hereby incorporated into the Procurement and Contracting Requirements by reference.
 - 1. A copy of the Instruction to Bidders Document is included in the Project Manual.

END OF DOCUMENT 002113

DOCUMENT 002513 - PREBID MEETING

1.1 PREBID MEETING

- A. Construction Solutions, Inc. will conduct a Pre-bid meeting as indicated below:
 - 1. Meeting Date: Thursday, March 1, 2018
 - 2. Meeting Time: 10:00 a.m., local time.

- B. Location: Beachcomber I Condominiums 413 1st Street South Jacksonville Beach, Florida 32250

- C. Attendance:
 - 1. Prime Bidders: Attendance at Pre-bid meeting is mandatory.
 - 2. Sub-contractors: Attendance at Pre-bid meeting is recommended.
 - 3. Notice: Bids will only be accepted from prime bidders represented on Pre-bid Meeting sign-in sheet.

- D. Bidder Questions: Submit written questions to be addressed at Pre-bid meeting minimum of **(2)** business days prior to meeting.

- E. Agenda: Pre-bid meeting agenda will include review of topics that may affect proper preparation and submittal of bids, including the following:
 - 1. Procurement and Contracting Requirements:
 - a. Instructions to Bidders.
 - b. Bid Form and Attachments.
 - c. Bid Submittal Requirements.
 - d. Bid Submittal Checklist.
 - e. Notice of Award.
 - 2. Communication during Bidding Period:
 - a. Obtaining documents.
 - b. Bidder's Requests for Information.
 - c. Bidder's Substitution Request/Prior Approval Request.
 - d. Addenda.
 - 3. Contracting Requirements:
 - a. Agreement.
 - b. The General Conditions.
 - c. The Supplementary Conditions.
 - d. Other Owner requirements.
 - 4. Construction Documents:
 - a. Scopes of Work.
 - b. Temporary Facilities.
 - c. Use of Site.
 - d. Work Restrictions.
 - e. Alternates, Allowances, and Unit Prices.
 - f. Substitutions following award.
 - 5. Schedule:
 - a. Project Schedule.
 - b. Contract Time.

- c. Other Bidder Questions.
 - d. Liquidated damages @ \$250 per day.
- 6. Site/facility visit or walkthrough.

- F. Minutes: Entity responsible for conducting meeting will record and distribute meeting minutes to attendees. Minutes of meeting are issued as Available Information and do not constitute a modification to the Procurement and Contracting Documents. Modifications to the Procurement and Contracting Documents are issued by written Addendum only.
 - 1. Sign-in Sheet: Minutes will include list of meeting attendees.

END OF DOCUMENT 002513

DOCUMENT 004113 - BID FORM - STIPULATED SUM (SINGLE-PRIME CONTRACT)

1.1 BID INFORMATION

- A. Bidder: _____.
- B. Project Name: Beachcomber I Condominium Repairs & Renovations.
- C. Project Location: 413 1st Street South Jacksonville Beach, Florida 32250
- D. Owner: Beachcomber I Condominium Association, Inc.
- E. Engineer: Construction Solutions, Inc.

1.2 CERTIFICATIONS AND BASE BID

- A. Base Bid, Single-Prime (All Trades) Contract: The undersigned Bidder, having carefully examined the Procurement and Contracting Requirements, Conditions of the Contract, Drawings, Specifications, and all subsequent Addenda, as prepared by Construction Solutions, Inc., having visited the site, and being familiar with all conditions and requirements of the Work, hereby agrees to furnish all material, labor, equipment and services, including all scheduled allowances, necessary to complete the construction of the above-named project, according to the requirements of the Procurement and Contracting Documents, for the stipulated sum of:
 - 1. See Document 004113.1 Bid Form Schedule spreadsheet.

1.3 SUBCONTRACTORS AND SUPPLIERS

- A. The following companies shall execute subcontracts for the portions of the Work indicated:
 - 1. Concrete Work: _____.
 - 2. Stucco Work: _____.
 - 3. Painting Work: _____.
 - 4. Deck Coating: _____.
 - 5. Handrails: _____.
 - 6. Structural Steel: _____.

1.4 TIME OF COMPLETION

- A. The undersigned Bidder proposes and agrees hereby to commence the Work of the Contract Documents on a date specified in a written Notice to Proceed to be issued by Engineer, and shall fully complete the Work within _____ calendar days.

1.5 ACKNOWLEDGEMENT OF ADDENDA

- A. The undersigned Bidder acknowledges receipt of and use of the following Addenda in the preparation of this Bid:
1. Addendum No. 1, dated _____.

1.6 BID SUPPLEMENTS

- A. The following supplements are a part of this Bid Form and are attached hereto.
1. Bid Form Supplement - Alternates.
 2. Bid Form Supplement - Unit Prices.
 3. Bid Form Supplement - Allowances.
 4. Bid Form Supplement - Bid Bond.

1.7 CONTRACTOR'S LICENSE

- A. The undersigned further states that it is a duly licensed contractor, for the type of work proposed, in Jacksonville, Duval County Florida, and that all fees, permits, etc., pursuant to submitting this proposal have been paid in full.

1.8 SUBMISSION OF BID

- A. Respectfully submitted this ____ day of _____, 2016.
- B. Submitted By: _____.
- C. Authorized Signature: _____.
- D. Signed By : _____ (Type or print name).
- E. Title: _____.
- F. Witness By : _____ (Hand-written signature).
- G. Attest : _____ (Hand-written signature).
- H. By : _____ (Type or print name).
- I. Title: _____.
- J. Street Address: _____.
- K. City, State, Zip: _____.
- L. Phone: _____.
- M. License No. : _____.

Beachcomber I Condominium
Jacksonville Beach, Florida

3/1/18

N. Federal ID No. : _____.

END OF DOCUMENT 004113

DOCUMENT 004393 - BID SUBMITTAL CHECKLIST

1.1 BID INFORMATION

- A. Bidder: _____.
- B. Prime Contract: _____.
- C. Project Name: Spinnakers Reach I Condominium Repairs & Renovations.
- D. Project Location: 413 1st Street South, Jacksonville Beach, Florida 32250.
- E. Owner: Beachcomber I Condominium Association, Inc.
- F. Engineer: Construction Solutions, Inc.
- G. Owner's Representative: Construction Solutions, Inc.

1.2 BIDDER'S CHECKLIST

- A. In an effort to assist the Bidder in properly completing all documentation required, the following checklist is provided for the Bidder's convenience. The Bidder is solely responsible for verifying compliance with bid submittal requirements.
- B. Attach this completed checklist to the outside of the Submittal envelope.
 - 1. Used the Bid Form provided in the Project Manual.
 - 2. Prepared the Bid Form as required by the Instructions to Bidders.
 - 3. Indicated on the Bid Form the Addenda received.
 - 4. Attached to the Bid Form: Bid Supplement Form - Allowances.
 - 5. Attached to the Bid Form: Bid Supplement Form - Unit Prices.
 - 6. Attached to the Bid Form: Bid Supplement Form - Alternates.
 - 7. Attached to the Bid Form: Proposed Schedule of Values Form.
 - 8. Attached to the Bid Form: Document 004113-1 Bid Form Schedule spreadsheet.
 - 9. Attached to the Bid Form: Bid Bond OR a certified check for the amount required.
 - 10. Bid envelope shows name and address of the Bidder.
 - 11. Bid envelope shows the Bidder's Contractor's License Number.
 - 12. Bid envelope day of Bid Opening shows name of Project being bid.
 - 13. Bid envelope shows name of Prime Contract being bid, if applicable.
 - 14. Bid envelope shows time and day of Bid Opening.
 - 15. Verified that the Bidder can provide executed Performance Bond and Labor and Material Bond.
 - 16. Verified that the Bidder can provide Certificates of Insurance in the amounts indicated.

END OF DOCUMENT 004393

SECTION 011000 - SUMMARY

PART 1 - GENERAL

1.1 RELATED DOCUMENTS

- A. Drawings and general provisions of the Contract, including General and Supplementary Conditions and other Division 01 Specification Sections, apply to this Section.

1.2 SUMMARY

- A. Section Includes:
 - 1. Project information.
 - 2. Work covered by Contract Documents.
 - 3. Phased construction.
 - 4. Work by Owner.
 - 5. Work under separate contracts.
 - 6. Future work.
 - 7. Purchase contracts.
 - 8. Owner-furnished products.
 - 9. Contractor-furnished, Owner-installed products.
 - 10. Access to site.
 - 11. Coordination with occupants.
 - 12. Work restrictions.
 - 13. Specification and drawing conventions.
 - 14. Miscellaneous provisions.

1.3 PROJECT INFORMATION

- A. Project Identification: Beachcomber I Condominium Repairs & Renovations.
 - 1. Project Location: 413 1st Street South, Jacksonville Beach, FL 32250.
- B. Owner: Beachcomber I Condominium Association, Inc., 413 1st Street South, Jacksonville, FL 32250.
 - 1. Owner's Representative: Construction Solutions, Inc.
- C. Engineer: Construction Solutions, Inc. 961687 Gateway Blvd., Suite 101B, Amelia Island, Florida 32034. Contact phone number is 904-714-5333.
- D. Construction Manager: Construction Solutions, Inc.
 - 1. Construction Manager has been engaged for this Project to serve as an advisor to Owner and to provide assistance in administering the Contract for Construction between Owner and Contractor, according to a separate contract between Owner and Construction Manager.

2. Construction Manager for this Project is Project's constructor. The terms "Construction Manager" and "Contractor" are synonymous.

1.4 WORK COVERED BY CONTRACT DOCUMENTS

- A. The Work of Project is defined by the Contract Documents and consists of the following:
 1. The project includes removal of all existing stucco and repair of walls as needed, new balcony framing, finishes, handrails and waterproofing, removal and replacement of all windows and sliding patio doors, concrete repairs on the slabs, beams, and columns of and below the second floor, removal of all first floor stud walls, removal and replacement of the stairwell, and repairs to structural steel.
- B. Type of Contract:
 1. Project will be constructed under a single prime contract.

1.5 WORK BY OWNER

- A. General: Cooperate fully with Owner so work may be carried out smoothly, without interfering with or delaying work under this Contract or work by Owner. Coordinate the Work of this Contract with work performed by Owner.
- B. Preceding Work: Owner will perform the following construction operations at Project site. Those operations are scheduled to be substantially complete before work under this Contract begins.
 1. Clear all balconies, walkways and remove wall accessories or any other items which would interrupt with the performance of the work. Trim back all trees and shrubbery from the structures.
- C. Concurrent Work: Owner will perform the following construction operations at Project site. Those operations will be conducted simultaneously with work under this Contract.
 1. Provide a designated storage location for contractor access equipment, and storage containers.

1.6 ACCESS TO SITE

- A. General: Contractor shall have full use of Project site for construction operations during construction period. Contractor's use of Project site is limited only by Owner's right to perform work or to retain other contractors on portions of Project.
- B. General: Contractor shall have limited use of Project site for construction operations as indicated on Drawings by the Contract limits and as indicated by requirements of this Section.
- C. Use of Site: Limit use of Project site to be determined during the Pre-Construction meeting. Do not disturb portions of Project site beyond areas in which the allowed Work is indicated.

- D. Retain first "Limits" Subparagraph below on projects where necessary to describe areas of a site where work is permitted. Expand to indicate areas of site where incursions are forbidden under any circumstances. See Evaluations for model text.
- E. Condition of Existing Building: Maintain portions of existing building affected by construction operations in a weather-tight condition throughout construction period. Repair damage caused by construction operations.

1.7 COORDINATION WITH OCCUPANTS

- A. Full Owner Occupancy: Owner will occupy site and building(s) during entire construction period. Cooperate with Owner during construction operations to minimize conflicts and facilitate Owner usage. Perform the Work so as not to interfere with Owner's day-to-day operations. Maintain existing exits unless otherwise indicated.
 - 1. Maintain access to existing walkways, corridors, and other adjacent occupied or used facilities. Do not close or obstruct walkways, corridors, or other occupied or used facilities without written permission from Owner and approval of authorities having jurisdiction.
 - 2. Notify Owner not less than **(72 hours)** in advance of activities that will affect Owner's operations.

1.8 WORK RESTRICTIONS

- A. Work Restrictions, General: Comply with restrictions on construction operations.
 - 1. Comply with limitations on use of public streets and with other requirements of authorities having jurisdiction.
- B. On-Site Work Hours: Limit work in the existing building to normal business working hours of 8:00 a.m. to 5:00 p.m., Monday through Friday, unless otherwise indicated.
- C. Existing Utility Interruptions: Do not interrupt utilities serving facilities occupied by Owner or others unless permitted under the following conditions and then only after providing temporary utility services according to requirements indicated:
 - 1. Notify **Owner** not less than **(two)** days in advance of proposed utility interruptions.
 - 2. Obtain **Owner's** written permission before proceeding with utility interruptions.
- D. Noise, Vibration, and Odors: Coordinate operations that may result in high levels of noise and vibration, odors, or other disruption to Owner occupancy with Owner.
 - 1. Notify **Owner** not less than **(2)** days in advance of proposed disruptive operations.
 - 2. Obtain **Owner's** written permission before proceeding with disruptive operations.
- E. Nonsmoking Building: Smoking is not permitted within the building or within **25 feet** of entrances, operable windows, or outdoor-air intakes. Smoking is only permitted in designated smoking areas established at the Pre-Con meeting.
- F. Controlled Substances: Use of controlled substances on the site is not permitted.

- G. Employee Identification: Contractor personnel working on Project site will wear shirts identifying their company or other means of identification on their hard hats.
- H. Employee Screening: Comply with Owner's requirements for drug and background screening of Contractor personnel working on Project site if requested.
 - 1. Maintain list of approved screened personnel with Owner's representative if required.

1.9 SPECIFICATION AND DRAWING CONVENTIONS

- A. Specification Content: The Specifications use certain conventions for the style of language and the intended meaning of certain terms, words, and phrases when used in particular situations. These conventions are as follows:
 - 1. Imperative mood and streamlined language are generally used in the Specifications. The words "shall," "shall be," or "shall comply with," depending on the context, are implied where a colon (:) is used within a sentence or phrase.
 - 2. Specification requirements are to be performed by Contractor unless specifically stated otherwise.
- B. Division 01 General Requirements: Requirements of Sections in Division 01 apply to the Work of all Sections in the Specifications.
- C. Drawing Coordination: Requirements for materials and products identified on Drawings are described in detail in the Specifications. One or more of the following are used on Drawings to identify materials and products:
 - 1. Terminology: Materials and products are identified by the typical generic terms used in the individual Specifications Sections.
 - 2. Abbreviations: Materials and products are identified by abbreviations published as part of the U.S. National CAD Standard and scheduled on Drawings.
 - 3. Keynoting: Materials and products are identified by reference keynotes referencing Specification Section numbers found in this Project Manual.

END OF SECTION 011000

SECTION 030130 - MAINTENANCE OF CAST-IN-PLACE CONCRETE

PART 1 - GENERAL

1.1 RELATED DOCUMENTS

- A. Drawings and general provisions of the Contract, including General and Supplementary Conditions and Division 01 Specification Sections, apply to this Section.

1.2 SUMMARY

- A. Section Includes:
 - 1. Removal of deteriorated concrete and subsequent replacement and patching.
 - 2. Epoxy crack injection.
 - 3. Corrosion-inhibiting treatment.

1.3 UNIT PRICES

- A. General: Unit prices include the cost of preparing existing construction to receive the work indicated and costs of field quality control required for units of work completed.
- B. Concrete Removal and Replacement or Patching: Work will be paid for by the cubic foot computed on the basis of rectangular solid shapes approximating the actual shape of concrete removed and replaced with average depths, widths, and lengths, measured to the nearest inch.
- C. Epoxy Crack Injection: Work will be paid for by the linear foot of crack injected.

1.4 PREINSTALLATION MEETINGS

- A. Preinstallation Conference: Conduct conference at Project site.

1.5 ACTION SUBMITTALS

- A. Product Data: For each type of product. Include construction details, material descriptions, chemical composition, physical properties, test data, and mixing, preparation, and application instructions.
- B. Samples: Cured samples for each exposed product and for each color and texture specified, in manufacturer's standard size appropriate for each type of work.
- C. Samples for Initial Selection: Cured samples for each exposed product and for each color and texture specified.

1. Include sets of patching-material Samples in the form of briquettes, at least 3 inches long by 1-1/2 inches wide representative of the range of concrete colors on the building. Document each Sample with product, mix, and or other information necessary to replicate it.
 2. Have each set of Samples contain a close color range of at least three Samples of different mixes of materials that match the variations in existing, adjacent concrete when cured and dry.
- D. Samples for Verification: Cured samples for each exposed product and for each color and texture specified.
1. Include Samples of each required type, color, and texture of patching material in the form of patches in drilled holes or sawed joints in sample concrete representative of the range of concrete colors on the building.

1.6 INFORMATIONAL SUBMITTALS

- A. Qualification Data: For installers and manufacturers.
- B. Material Certificates: For each type of Portland cement & aggregate supplied for mixing or adding to products at Project site.
- C. Product Test Reports: For each manufactured bonding agent, cementitious patching mortar, crack injection, and sealer, for tests performed by manufacturer and witnessed by a qualified testing agency.
- D. Field quality-control reports.
- E. Maintenance Program: Submit before work begins.

1.7 QUALITY ASSURANCE

- A. Manufacturer Qualifications: Each manufactured bonding-agent, cementitious patching-mortar, and crack-injection-adhesive manufacturer shall employ factory-trained technical representatives who are available for consultation and Project-site inspection and assistance at no additional cost.
- B. Installer Qualifications: An entity that employs installers and supervisors who are trained and approved by manufacturer to apply packaged patching-mortar materials epoxy crack injection materials and corrosion-inhibiting treatments.
- C. Maintenance Program: Prepare a written plan for maintenance of cast-in-place concrete, including each phase or process, protection of surrounding materials during operations, and control of debris and runoff during the Work. Describe in detail materials, methods, equipment, and sequence of operations to be used for each phase of the Work.

1.8 DELIVERY, STORAGE, AND HANDLING

- A. Comply with manufacturer's written instructions for minimum and maximum temperature requirements and other conditions for storage.
- B. Store cementitious materials off the ground, under cover, and in a dry location.
- C. Store aggregates covered and in a dry location; maintain grading and other required characteristics and prevent contamination.

1.9 FIELD CONDITIONS

- A. Environmental Limitations for Epoxies: Do not apply when air and substrate temperatures are outside limits permitted by manufacturer. During hot weather, cool epoxy components before mixing, store mixed products in shade, and cool unused mixed products to retard setting. Do not apply to wet substrates unless approved by manufacturer.
 - 1. Use only Class A epoxies when substrate temperatures are below or are expected to go below 40 deg F within 8 hours.
 - 2. Use only Class A or B epoxies when substrate temperatures are below or are expected to go below 60 deg F within 8 hours.
 - 3. Use only Class C epoxies when substrate temperatures are above and are expected to stay above 60 deg F for 8 hours.
- B. Cold-Weather Requirements for Cementitious Materials: Comply with the following procedures:
 - 1. When air temperature is below 40 deg F, heat patching-material ingredients and existing concrete to produce temperatures between 40 and 90 deg F.
 - 2. When mean daily air temperature is between 25 and 40 deg F, cover completed Work with weather-resistant insulating blankets for 48 hours after repair or provide enclosure and heat to maintain temperatures above 32 deg F within the enclosure for 48 hours after repair.
 - 3. When mean daily air temperature is below 25 deg F, provide enclosure and heat to maintain temperatures above 32 deg F within the enclosure for 48 hours after repair.
- C. Hot-Weather Requirements for Cementitious Materials: Protect repair work when temperature and humidity conditions produce excessive evaporation of water from patching materials. Provide artificial shade and wind breaks, and use cooled materials as required. Do not apply to substrates with temperatures of 90 deg F and above.

PART 2 - PRODUCTS

2.1 MATERIALS, GENERAL

- A. Source Limitations: Obtain each color, grade, finish, type, and variety of product from single source with resources to provide products of consistent quality in appearance and physical properties.

2.2 BONDING AGENTS

- A. Epoxy-Modified, Cementitious Bonding and Anticorrosion Agent: Manufactured product that consists of water-insensitive epoxy adhesive, portland cement, and water-based solution of corrosion-inhibiting chemicals that forms a protective film on steel reinforcement.
1. Products: Subject to compliance with requirements, provide one of the following available products that may be incorporated into the Work include, but are not limited to, the following:
 - a. BASF Construction Chemicals - Building Systems; Emaco P24.
 - b. Euclid Chemical Company (The), an RPM company; Duralprep A.C.
 - c. Sika Corporation, Construction Product Division; Armatec 110 or EpoCem.

2.3 PATCHING MORTAR

- A. Patching Mortar, General:
1. Only use patching mortars that are recommended by manufacturer for each applicable horizontal, vertical, or overhead use orientation.
 2. Coarse Aggregate for Patching Mortar: ASTM C 33, washed aggregate, Size No. 8, Class 5S. Add to patching-mortar mix only as permitted by patching-mortar manufacturer.
- B. Job-Mixed Patching Mortar: 1 part portland cement and 2-1/2 parts fine aggregate complying with ASTM C 144, except 100 percent passing a No. 16 sieve.
- C. Cementitious Patching Mortar: Packaged, dry mix for repair of concrete.
1. Basis-of-Design Product: Subject to compliance with requirements, provide product indicated on Drawings or comparable product by one of the following:
 - a. BASF Construction Chemicals - Building Systems.
 - b. Euclid Chemical Company (The); an RPM company.
 - c. Sika Corporation; Construction Product Division.
 2. Compressive Strength: Not less than 4000 psi at 28 days when tested according to ASTM C 109/C 109M.
- D. Rapid-Strengthening, Cementitious Patching Mortar: Packaged, dry mix, ASTM C 928 for repair of concrete.
1. Basis-of-Design Product: Subject to compliance with requirements, provide product indicated on Drawings or comparable product by one of the following:
 - a. BASF Construction Chemicals - Building Systems.
 - b. Euclid Chemical Company (The); an RPM company.
 - c. Sika Corporation; Construction Product Division.
 2. Compressive Strength: Not less than 4000 psi within four hours when tested according to ASTM C 109/C 109M.
- E. Polymer-Modified, Cementitious Patching Mortar: Packaged, dry mix for repair of concrete and that contains a non-redispersible latex additive as either a dry powder or a separate liquid that is added during mixing.

1. Basis-of-Design Product: Subject to compliance with requirements, provide product indicated on Drawings or comparable product by one of the following:
 - a. BASF Construction Chemicals - Building Systems.
 - b. Euclid Chemical Company (The); an RPM company.
 - c. Sika Corporation; Construction Product Division.
 2. Compressive Strength: Not less than 5000 psi at 28 days when tested according to ASTM C 109/C 109M.
- F. Polymer-Modified, Silica-Fume-Enhanced, Cementitious Patching Mortar: Packaged, dry mix for repair of concrete and that contains silica fume complying with ASTM C 1240 and a non-redispersible latex additive as either a dry powder or a separate liquid that is added during mixing.
1. Basis-of-Design Product: Subject to compliance with requirements, provide product indicated on Drawings or comparable product by one of the following:
 - a. BASF Construction Chemicals - Building Systems.
 - b. Euclid Chemical Company (The); an RPM company.
 - c. Sika Corporation; Construction Product Division.
 2. Compressive Strength: Not less than 5000 psi at 28 days when tested according to ASTM C 109/C 109M.

2.4 EPOXY CRACK-INJECTION MATERIALS

- A. Epoxy Crack-Injection Adhesive: ASTM C 881/C 881M, Type IV at structural locations and where indicated, Type I at other locations; free of VOCs.
1. Basis-of-Design Product: Subject to compliance with requirements, provide product indicated on Drawings or comparable product by one of the following:
 - a. BASF Construction Chemicals - Building Systems.
 - b. Euclid Chemical Company (The); an RPM company.
 - c. Sika Corporation; Construction Product Division.
 2. Capping Adhesive: Product manufactured for use with crack injection adhesive by same manufacturer.

2.5 OTHER MATERIALS

- A. Portland Cement: ASTM C 150, Type I, II, or III unless otherwise indicated.

2.6 MIXES

- A. General: Mix products, in clean containers, according to manufacturer's written instructions.
1. Do not add water, thinners, or additives unless recommended by manufacturer.
 2. When practical, use manufacturer's premeasured packages to ensure that materials are mixed in proper proportions. When premeasured packages are not used, measure ingredients using graduated measuring containers; do not estimate quantities or use shovel or trowel as unit of measure.
 3. Do not mix more materials than can be used within time limits recommended by manufacturer. Discard materials that have begun to set.

- B. Dry-Pack Mortar: Mix patching-mortar dry ingredients with just enough liquid to form damp cohesive mixture that can be squeezed by hand into a ball but is not plastic.
- C. Concrete: Comply with Section 033000 "Cast-in-Place Concrete" Section 033053 "Miscellaneous Cast-in-Place Concrete".

PART 3 - EXECUTION

3.1 EXAMINATION

- A. Notify Architect seven days in advance of dates when areas of deteriorated or delaminated concrete and deteriorated reinforcing bars will be located.
- B. Locate areas of deteriorated or delaminated concrete using hammer or chain-drag sounding and mark boundaries. Mark areas for removal by simplifying and squaring off boundaries as directed by Architect. At columns and walls make boundaries level and plumb unless otherwise indicated.
- C. Perform surveys as the Work progresses to detect hazards resulting from concrete-maintenance work.

3.2 PREPARATION

- A. Ensure that supervisory personnel are on-site and on duty when concrete maintenance work begins and during its progress.
- B. Preparation for Removal of Deteriorated Concrete: Examine construction to be repaired to determine best methods to safely and effectively perform concrete maintenance work. Examine adjacent work to determine what protective measures will be necessary. Make explorations, probes, and inquiries as necessary to determine condition of construction to be removed in the course of repair.
 - 1. Verify that affected utilities have been disconnected and capped.
 - 2. Inventory and record the condition of items to be removed for reinstallation or salvage.
 - 3. Provide and maintain shoring, bracing, and temporary structural supports as required to preserve stability and prevent unexpected or uncontrolled movement, settlement, or collapse of construction being demolished and construction and finishes to remain.
- C. Protect persons, motor vehicles, surrounding surfaces of building being restored, building site, plants, and surrounding buildings from harm resulting from concrete maintenance work.
 - 1. Comply with each product manufacturer's written instructions for protections and precautions. Protect against adverse effects of products and procedures on people and adjacent materials, components, and vegetation.
 - 2. Use only proven protection methods appropriate to each area and surface being protected.
 - 3. Provide barricades, barriers, and temporary directional signage to exclude public from areas where concrete maintenance work is being performed.

4. Erect temporary protective covers over walkways and at points of pedestrian and vehicular entrance and exit that must remain in service during course of concrete maintenance work.
 5. Contain dust and debris generated by concrete maintenance work and prevent it from reaching the public or adjacent surfaces.
 6. Use water-mist sprinkling and other wet methods to control dust only with adequate, approved procedures and equipment that ensure that such water will not create a hazard or adversely affect other building areas or materials.
 7. Protect floors and other surfaces along haul routes from damage, wear, and staining.
 8. Protect adjacent surfaces and equipment by covering them with heavy polyethylene film and waterproof masking tape or a liquid strippable masking agent. If practical, remove items, store, and reinstall after potentially damaging operations are complete.
 9. Neutralize and collect alkaline and acid wastes for disposal off Owner's property.
 10. Dispose of debris and runoff from operations by legal means and in a manner that prevents soil erosion, undermining of paving and foundations, damage to landscaping, and water penetration into building interiors.
- D. Existing Drains: Prior to the start of work in an area, test drainage system to ensure that it is functioning properly. Notify Architect immediately of inadequate drainage or blockage. Do not begin work in an area until the drainage system is in working order.
1. Prevent solids such as aggregate or mortar residue from entering the drainage system. Clean out drains and drain lines that become sluggish or blocked by sand or other materials resulting from concrete maintenance work.
 2. Protect drains from pollutants. Block drains or filter out sediments, allowing only clean water to pass.
- E. Concrete Removal:
1. Provide shoring, bracing, and supports as necessary. Strengthen or add new supports when required during progress of removal work. Do not overload structural elements with debris.
 2. Saw-cut perimeter of areas indicated for removal to a depth of at least 1/2 inch. Make cuts perpendicular to concrete surfaces and no deeper than cover on reinforcement.
 3. Remove deteriorated and delaminated concrete by breaking up and dislodging from reinforcement.
 4. Remove additional concrete if necessary to provide a depth of removal of at least 1/2 inch over entire removal area.
 5. Where half or more of the perimeter of reinforcing bar is exposed, bond between reinforcing bar and surrounding concrete is broken, or reinforcing bar is corroded, remove concrete from entire perimeter of bar and to provide at least a 3/4-inch clearance around bar.
 6. Test areas where concrete has been removed by tapping with hammer, and remove additional concrete until unsound and disbonded concrete is completely removed.
 7. Provide surfaces with a fractured profile of at least 1/8 inch that are approximately perpendicular or parallel to original concrete surfaces. At columns and walls, make top and bottom surfaces level unless otherwise directed.
 8. Thoroughly clean removal areas of loose concrete, dust, and debris.

- F. Reinforcing-Bar Preparation: Remove loose and flaking rust from reinforcing bars by high-pressure water cleaning abrasive blast cleaning needle scaling or wire brushing until only tightly adhered light rust remains.
 - 1. Where section loss of reinforcing bar is more than 20 percent, cut bars, remove and replace as directed by Engineer. Remove additional concrete as necessary to provide at least 3/4-inch clearance at existing and replacement bars. Splice replacement bars to existing bars according to ACI 318 by lapping, welding, or using mechanical couplings.

3.3 APPLICATION

- A. General: Comply with manufacturer's written instructions and recommendations for application of products, including surface preparation.
- B. Epoxy-Modified, Cementitious Bonding and Anticorrosion Agent: Apply to reinforcing bars and concrete by stiff brush or hopper spray according to manufacturer's written instructions. Apply to reinforcing bars in two coats, allowing first coat to dry two to three hours before applying second coat. Allow to dry before placing patching mortar or concrete.
- C. Placing Patching Mortar: Place as follows unless otherwise recommended in writing by manufacturer:
 - 1. Provide forms where necessary to confine patch to required shape.
 - 2. Wet substrate and forms thoroughly and then remove standing water.
 - 3. Pretreatment: Apply specified bonding agent.
 - 4. General Placement: Place patching mortar by troweling toward edges of patch to force intimate contact with edge surfaces. For large patches, fill edges first and then work toward center, always troweling toward edges of patch. At fully exposed reinforcing bars, force patching mortar to fill space behind bars by compacting with trowel from sides of bars.
 - 5. Vertical Patching: Place material in lifts of not more than as recommended by the manufacturer nor less than 1/4 inch. Do not feather edge.
 - 6. Overhead Patching: Place material in lifts of not more than as recommended by the manufacturer nor less than 1/4 inch. Do not feather edge.
 - 7. Consolidation: After each lift is placed, consolidate material and screed surface.
 - 8. Multiple Lifts: Where multiple lifts are used, score surface of lifts to provide a rough surface for placing subsequent lifts. Allow each lift to reach final set before placing subsequent lifts.
 - 9. Finishing: Allow surfaces of lifts that are to remain exposed to become firm and then finish to a surface matching adjacent concrete.
 - 10. Curing: Wet-cure cementitious patching materials, including polymer-modified cementitious patching materials, for not less than seven days by water-fog spray or water-saturated absorptive cover.
- D. Dry-Pack Mortar: Use for deep cavities. Place as follows unless otherwise recommended in writing by manufacturer:
 - 1. Provide forms where necessary to confine patch to required shape.
 - 2. Wet substrate and forms thoroughly and then remove standing water.
 - 3. Pretreatment: Apply specified bonding agent.

4. Place dry-pack mortar into cavity by hand, and compact tightly into place. Do not place more material at a time than can be properly compacted. Continue placing and compacting until patch is approximately level with surrounding surface.
 5. After cavity is filled and patch is compacted, trowel surface to match profile and finish of surrounding concrete. A thin coat of patching mortar may be troweled into the surface of patch to help obtain required finish.
 6. Wet-cure patch for not less than seven days by water-fog spray or water-saturated absorptive cover.
- E. Concrete: Place according to Section 033000 "Cast-in-Place Concrete" Section 033053 "Miscellaneous Cast-in-Place Concrete" and as follows:
1. Pretreatment: Apply epoxy-modified, cementitious bonding and anticorrosion agent to reinforcement and concrete substrate.
 2. Standard Placement:
 - a. Use vibrators to consolidate concrete as it is placed.
 - b. At unformed surfaces, screed concrete to produce a surface that when finished with patching mortar will match required profile and surrounding concrete.
 3. Form-and-Pump Placement: Place concrete where indicated by form and pump method.
 - a. Design and construct forms to resist pumping pressure in addition to weight of wet concrete. Seal joints and seams in forms and where forms abut existing concrete.
 - b. Pump concrete into place from bottom to top, releasing air from forms as concrete is introduced. When formed space is full, close air vents and pressurize to 14 psi.
 4. Wet-cure concrete for not less than seven days by leaving forms in place or keeping surfaces continuously wet by water-fog spray or water-saturated absorptive cover.
 5. Fill placement cavities with dry-pack mortar and repair voids with patching mortar. Finish to match surrounding concrete.
- F. Epoxy Crack Injection:
1. Clean areas to receive capping adhesive of oil, dirt, and other substances that would interfere with bond, and clean cracks with oil-free compressed air or low-pressure water to remove loose particles.
 2. Place injection ports as recommended by epoxy manufacturer, spacing no farther apart than thickness of member being injected. Seal injection ports in place with capping adhesive.
 3. Seal cracks at exposed surfaces with a ribbon of capping adhesive at least 1/4 inch thick by 1 inch wider than crack.
 4. Inject cracks wider than 0.003 inch to a depth of 8 inches.
 5. Inject epoxy adhesive, beginning at widest part of crack and working toward narrower parts. Inject adhesive into ports to refusal, capping adjacent ports when they extrude epoxy. Cap injected ports and inject through adjacent ports until crack is filled.
 6. After epoxy adhesive has set, remove injection ports and grind surfaces smooth.

3.4 FIELD QUALITY CONTROL

- A. Testing Agency: Engage a qualified testing agency to perform tests and inspections.

- B. Perform the following tests and inspections:
 - 1. Packaged, Cementitious Patching Mortar: Three randomly selected sets of samples for each type of mortar required, tested according to ASTM C 928.
 - 2. Job-Mixed Patching Mortar: Three randomly selected sets of samples for each type of mortar required, tested for compressive strength according to ASTM C 109/C 109M.
 - 3. Concrete: As specified in Section 033000 "Cast-in-Place Concrete" Section 033053 "Miscellaneous Cast-in-Place Concrete"
 - 4. Epoxy Crack Injection: Core-drilled samples to verify proper installation.
 - a. Testing Frequency: 1 sample for each 100 feet of crack injected.
 - b. Where samples are taken, refill holes with epoxy mortar.
- C. Product will be considered defective if it does not pass tests and inspections.
- D. Prepare test and inspection reports.

END OF SECTION 030130

SECTION 033000 - CAST-IN-PLACE CONCRETE

PART 1 - GENERAL

1.1 SUMMARY

- A. Section includes cast-in-place concrete, including formwork, reinforcement, concrete materials, mixture design, placement procedures, and finishes.

1.2 ACTION SUBMITTALS

- A. Product Data: For each type of product.
- B. Design Mixtures: For each concrete mixture.
- C. Steel Reinforcement Shop Drawings: Placing Drawings that detail fabrication, bending, and placement.

1.3 INFORMATIONAL SUBMITTALS

- A. Material certificates.
- B. Material test reports.

1.4 QUALITY ASSURANCE

- A. Manufacturer Qualifications: A firm experienced in manufacturing ready-mixed concrete products and that complies with ASTM C 94/C 94M requirements for production facilities and equipment.
 - 1. Manufacturer certified according to NRMCA's "Certification of Ready Mixed Concrete Production Facilities."
- B. Testing Agency Qualifications: An independent agency, acceptable to authorities having jurisdiction, qualified according to ASTM C 1077 and ASTM E 329 for testing indicated.

1.5 PRECONSTRUCTION TESTING

- A. Preconstruction Testing Service: Engage a qualified testing agency to perform preconstruction testing on concrete mixtures.

1.6 FIELD CONDITIONS

- A. Cold-Weather Placement: Comply with ACI 306.1.
 - 1. Do not use calcium chloride, salt, or other materials containing antifreeze agents or chemical accelerators unless otherwise specified and approved in mixture designs.
- B. Hot-Weather Placement: Comply with ACI 301 .

PART 2 - PRODUCTS

2.1 CONCRETE, GENERAL

- A. ACI Publications: Comply with the following unless modified by requirements in the Contract Documents:
 - 1. ACI 301.
 - 2. ACI 117.

2.2 FORM-FACING MATERIALS

- A. Smooth-Formed Finished Concrete: Form-facing panels that provide continuous, true, and smooth concrete surfaces. Furnish in largest practicable sizes to minimize number of joints.

2.3 STEEL REINFORCEMENT

- A. Reinforcing Bars: ASTM A 615/A 615M, Grade 60 , deformed.
- B. Plain-Steel Welded-Wire Reinforcement: ASTM A 1064/A 1064M, plain, fabricated from as-drawn steel wire into flat sheets.
- C. Bar Supports: Bolsters, chairs, spacers, and other devices for spacing, supporting, and fastening reinforcing bars and welded-wire reinforcement in place. Manufacture bar supports from steel wire, plastic, or precast concrete according to CRSI's "Manual of Standard Practice."

2.4 CONCRETE MATERIALS

- A. Cementitious Materials:
 - 1. Portland Cement: ASTM C 150/C 150M.
 - 2. Fly Ash: ASTM C 618, **Class F**.
 - 3. Slag Cement: ASTM C 989/C 989M, Grade 100 or 120.
- B. Normal-Weight Aggregates: ASTM C 33/C 33M, graded.

1. Maximum Coarse-Aggregate Size: 1 inch nominal.
 2. Fine Aggregate: Free of materials with deleterious reactivity to alkali in cement.
- C. Air-Entraining Admixture: ASTM C 260/C 260M.
- D. Chemical Admixtures: Certified by manufacturer to be compatible with other admixtures and that do not contribute water-soluble chloride ions exceeding those permitted in hardened concrete. Do not use calcium chloride or admixtures containing calcium chloride.
1. Water-Reducing Admixture: ASTM C 494/C 494M, Type A.
 2. Retarding Admixture: ASTM C 494/C 494M, Type B.
 3. Water-Reducing and Retarding Admixture: ASTM C 494/C 494M, Type D.
 4. High-Range, Water-Reducing Admixture: ASTM C 494/C 494M, Type F.
 5. High-Range, Water-Reducing and Retarding Admixture: ASTM C 494/C 494M, Type G.
 6. Plasticizing and Retarding Admixture: ASTM C 1017/C 1017M, Type II.
- E. Water: ASTM C 94/C 94M and potable.

2.5 VAPOR RETARDERS

- A. Sheet Vapor Retarder: Polyethylene sheet, ASTM D 4397, not less than 10 mils thick.

2.6 CURING MATERIALS

- A. Evaporation Retarder: Waterborne, monomolecular film forming, manufactured for application to fresh concrete.
- B. Absorptive Cover: AASHTO M 182, Class 2, burlap cloth made from jute or kenaf, weighing approximately 9 oz./sq. yd. when dry.
- C. Moisture-Retaining Cover: ASTM C 171, polyethylene film or white burlap-polyethylene sheet.
- D. Water: Potable.
- E. Clear, Waterborne, Membrane-Forming Curing Compound: ASTM C 309, Type 1, Class B, dissipating.

2.7 RELATED MATERIALS

- A. Expansion- and Isolation-Joint-Filler Strips: ASTM D 1751, asphalt-saturated cellulosic fiber.

2.8 CONCRETE MIXTURES, GENERAL

- A. Prepare design mixtures for each type and strength of concrete, proportioned on the basis of laboratory trial mixture or field test data, or both, according to ACI 301.

- B. Cementitious Materials: Use fly ash, pozzolan, slag cement, and silica fume as needed to reduce the total amount of Portland cement, which would otherwise be used, by not less than 40 percent.
- C. Admixtures: Use admixtures according to manufacturer's written instructions.
 - 1. Use water-reducing or plasticizing admixture in concrete, as required, for placement and workability.
 - 2. Use water-reducing and -retarding admixture when required by high temperatures, low humidity, or other adverse placement conditions.
 - 3. Use water-reducing admixture in pumped concrete, concrete for heavy-use industrial slabs and parking structure slabs, concrete required to be watertight, and concrete with a w/c ratio below 0.50.

2.9 CONCRETE MIXTURES FOR BUILDING ELEMENTS

- A. Normal-Weight Concrete:
 - 1. Minimum Compressive Strength: 3000 psi strength at 28 days.
 - 2. Maximum W/C Ratio: 0.50.
 - 3. Slump Limit: 5 inches, plus or minus 1 inch .
 - 4. Air Content: 6 percent, plus or minus 1.5 percent at point of delivery.

2.10 FABRICATING REINFORCEMENT

- A. Fabricate steel reinforcement according to CRSI's "Manual of Standard Practice."

2.11 CONCRETE MIXING

- A. Ready-Mixed Concrete: Measure, batch, mix, and deliver concrete according to ASTM C 94/C 94M, and furnish batch ticket information.
 - 1. When air temperature is between 85 and 90 deg F, reduce mixing and delivery time from 1-1/2 hours to 75 minutes; when air temperature is above 90 deg F, reduce mixing and delivery time to 60 minutes.

PART 3 - EXECUTION

3.1 FORMWORK INSTALLATION

- A. Design, erect, shore, brace, and maintain formwork, according to ACI 301, to support vertical, lateral, static, and dynamic loads, and construction loads that might be applied, until structure can support such loads.

- B. Construct formwork so concrete members and structures are of size, shape, alignment, elevation, and position indicated, within tolerance limits of ACI 117.
- C. Chamfer exterior corners and edges of permanently exposed concrete.

3.2 EMBEDDED ITEM INSTALLATION

- A. Place and secure anchorage devices and other embedded items required for adjoining work that is attached to or supported by cast-in-place concrete. Use setting drawings, templates, diagrams, instructions, and directions furnished with items to be embedded.

3.3 VAPOR-RETARDER INSTALLATION

- A. Sheet Vapor Retarders: Place, protect, and repair sheet vapor retarder according to ASTM E 1643 and manufacturer's written instructions.
 - 1. Lap joints 6 inches and seal with manufacturer's recommended tape.

3.4 STEEL REINFORCEMENT INSTALLATION

- A. General: Comply with CRSI's "Manual of Standard Practice" for fabricating, placing, and supporting reinforcement.
 - 1. Do not cut or puncture vapor retarder. Repair damage and reseal vapor retarder before placing concrete.

3.5 JOINTS

- A. General: Construct joints true to line with faces perpendicular to surface plane of concrete.
- B. Construction Joints: Install so strength and appearance of concrete are not impaired, at locations indicated or as approved by Architect.
- C. Isolation Joints in Slabs-on-Grade: After removing formwork, install joint-filler strips at slab junctions with vertical surfaces, such as column pedestals, foundation walls, grade beams, and other locations, as indicated.

3.6 CONCRETE PLACEMENT

- A. Before placing concrete, verify that installation of formwork, reinforcement, and embedded items is complete and that required inspections are completed.
- B. Deposit concrete continuously in one layer or in horizontal layers of such thickness that no new concrete is placed on concrete that has hardened enough to cause seams or planes of

weakness. If a section cannot be placed continuously, provide construction joints as indicated. Deposit concrete to avoid segregation.

1. Consolidate placed concrete with mechanical vibrating equipment according to ACI 301.

3.7 FINISHING FORMED SURFACES

- A. Rough-Formed Finish: As-cast concrete texture imparted by form-facing material with tie holes and defects repaired and patched. Remove fins and other projections that exceed specified limits on formed-surface irregularities.

1. Apply to concrete surfaces not exposed to public view.

- B. Smooth-Formed Finish: As-cast concrete texture imparted by form-facing material, arranged in an orderly and symmetrical manner with a minimum of seams. Repair and patch tie holes and defects. Remove fins and other projections that exceed specified limits on formed-surface irregularities.

1. Apply to concrete surfaces exposed to public view.

- C. Related Unformed Surfaces: At tops of walls, horizontal offsets, and similar unformed surfaces adjacent to formed surfaces, strike off smooth and finish with a texture matching adjacent formed surfaces. Continue final surface treatment of formed surfaces uniformly across adjacent unformed surfaces unless otherwise indicated.

3.8 FINISHING FLOORS AND SLABS

- A. General: Comply with ACI 302.1R recommendations for screeding, restraightening, and finishing operations for concrete surfaces. Do not wet concrete surfaces.

- B. Scratch Finish: While still plastic, texture concrete surface that has been screeded and bull-floated or darbied. Use stiff brushes, brooms, or rakes to produce a profile amplitude of 1/4 inch in one direction.

1. Apply scratch finish to all surfaces.

- C. Trowel Finish: After applying float finish, apply first troweling and consolidate concrete by hand or power-driven trowel. Continue troweling passes and restraighten until surface is free of trowel marks and uniform in texture and appearance. Grind smooth any surface defects that would telegraph through applied coatings or floor coverings.

1. Apply a trowel finish to all surfaces.

- D. Trowel and Fine-Broom Finish: Apply a first trowel finish to all surfaces. While concrete is still plastic, slightly scarify surface with a fine broom.

1. Comply with flatness and levelness tolerances for trowel-finished floor surfaces.

3.9 CONCRETE PROTECTING AND CURING

- A. General: Protect freshly placed concrete from premature drying and excessive cold or hot temperatures. Comply with ACI 306.1 for cold-weather protection and ACI 301 for hot-weather protection during curing.
- B. Evaporation Retarder: Apply evaporation retarder to unformed concrete surfaces if hot, dry, or windy conditions cause moisture loss approaching 0.2 lb/sq. ft. x h before and during finishing operations. Apply according to manufacturer's written instructions after placing, screeding, and bull floating or darbying concrete, but before float finishing.
- C. Formed Surfaces: Cure formed concrete surfaces, including underside of beams, supported slabs, and other similar surfaces. If forms remain during curing period, moist cure after loosening forms. If removing forms before end of curing period, continue curing for remainder of curing period.
- D. Cure concrete according to ACI 308.1, by one or a combination of the following methods:
 - 1. Moisture Curing: Keep surfaces continuously moist for not less than seven days.
 - 2. Moisture-Retaining-Cover Curing: Cover concrete surfaces with moisture-retaining cover for curing concrete, placed in widest practicable width, with sides and ends lapped at least 12 inches, and sealed by waterproof tape or adhesive. Cure for not less than seven days. Immediately repair any holes or tears during curing period, using cover material and waterproof tape.
 - 3. Curing Compound: Apply uniformly in continuous operation by power spray or roller according to manufacturer's written instructions. Recoat areas subjected to heavy rainfall within three hours after initial application. Maintain continuity of coating and repair damage during curing period.
 - a. Removal: After curing period has elapsed, remove curing compound without damaging concrete surfaces by method recommended by curing compound manufacturer.
 - 4. Curing and Sealing Compound: Apply uniformly to floors and slabs indicated in a continuous operation by power spray or roller according to manufacturer's written instructions. Recoat areas subjected to heavy rainfall within three hours after initial application. Repeat process 24 hours later and apply a second coat. Maintain continuity of coating and repair damage during curing period.

3.10 CONCRETE SURFACE REPAIRS

- A. Defective Concrete: Repair and patch defective areas when approved by Architect. Remove and replace concrete that cannot be repaired and patched to Architect's approval.

3.11 FIELD QUALITY CONTROL

- A. Special Inspections: Owner will engage a qualified testing and inspecting agency to perform field tests and inspections and prepare test reports.

END OF SECTION 033000

SECTION 054050 - COLD FORMED METAL FRAMING REPAIRS

PART 1 - GENERAL

1.1 RELATED DOCUMENTS

- A. Drawings and general provisions of the Contract, including General and Supplementary Conditions and Division 01 Specification Sections, apply to this Section.

1.2 SUMMARY

- A. Section Includes
 - 1. Repair of metal stud framed walls, as required, due to deterioration of the existing framing.

1.3 REFERENCES

- A. American Iron and Steel Institute (AISI):
 - 1. Most recent edition of the specification for the Design of Cold-Formed Steel Structural Members.
- B. American Society for Testing and Materials (ASTM):
 - 1. ASTM A36, "Carbon Structural Steel."
 - 2. ASTM A653, "Steel Sheet, Zinc-Coated (Galvanized) or Zinc-Iron Alloy-Coated (Galvannealed) by the Hot-Dip Process."
 - 3. ASTM A525 "Specification for General Requirements for Steel Sheet, Zinc Coated by the Hot Dip Process."
- C. American Welding Society (AWS):
 - 1. AWS D1.1, "Structural Welding Code."
- D. Steel Stud Manufacturers association (SSMS):
 - 1. Guidelines contained in ICBO ER-4943.

1.4 SUBMITTALS

- A. Product data: Include manufacturer's description of framing, load tables and installation data. Mark material to indicate only products proposed for use.
- B. Welders qualifications in accordance with American Welding Society Standard D1.1.
- C. Shop drawings: Submit shop drawings showing fabrication and erection procedures. Show locations, sizes and types of framing components and details of connections. Drawings shall indicate sequence and method of erection details of all connections of light gage steel framing to other elements of the building structure.
 - 1. Design Criteria: Submit calculations and shop drawings signed and sealed by registered professional engineer licensed to practice in the state of Florida.

1.5 SYSTEM DESCRIPTION

- A. Purpose of cold formed steel framing is to provide plumb and true surface for installation of exterior insulation and finish/and interior finish systems. Install framing within coordinated allowable tolerances.

1.6 DELIVERY AND STORAGE

- A. Deliver materials in unbroken bundles with each type of member identified with permanent marking. Store in protected area.

1.7 JOB CONDITIONS

- A. Existing conditions: Inspect structure for compliance with specified erection tolerances. Beginning work indicates an acceptance of conditions.
- B. Coordinate installation and location of anchors and inserts with structural system to which light gage steel framing is attached. Take care to avoid impact to pre- or post-tensioned steel strands potentially present in the concrete floor slabs.

1.8 QUALITY CRITERIA

- A. Qualifications of Welders:

1. Welders employed on the work shall have passed qualification tests within the past 12 months in the position for which qualified, using test procedures covered in the AWS D1.1.
2. Contractor shall require any welder to retake the qualification test when, in the opinion of the Architect, the work of the welder creates a reasonable doubt as to the proficiency of the welder. Requalification tests shall be conducted at no additional expense to the Owner. Recertification shall be made to Architect after the welder has passed the retest.

B. Quality Assurance:

1. Design Criteria:
 - a. Meet strength and deflection design criteria for wind loading as required by local governing code.
 - b. Interior wall stud deflection: Maximum $L/360$ in any single span.
 - c. Exterior wall stud deflection: Maximum $L/600$ in any single span (brick veneer).
 - d. Exterior wall stud deflection: Maximum $L/240$ in any single span (Brittle finishes)
2. Comply with governing codes and regulations. Provide products of acceptable manufacturers, which have been in satisfactory use in similar service for three years. Use experienced installers.
3. Welder's certifications: Employ welders currently qualified under AWS standard qualification procedures to perform type of require work.
4. All temporary utility services, including toilet facilities, are to be obtained and paid for by the contractor performing the work described herein.
5. Contractor is responsible for the protection of the public and all construction workers and must comply with all pertinent OSHA safety requirements throughout the duration of the work.
6. Contractor is responsible for all means and methods to complete the repairs.
7. All work shall be performed in strict accordance with the most recent edition of the Florida Building Code (FBC).
8. Contractor is responsible for obtaining all permits required for the completion of the work described below.

PART 2 - PRODUCTS

2.1 LIGHT GAGE STEEL FRAMING

- A. Acceptable manufacturers:
 - 1. Inryco, Inc.
 - 2. U.S. Gypsum Co.
 - 3. U.S. Steel Corp.
 - 4. Wheeling Corrugating Co.

- B. Metal studs and runners: Channel type, roll-formed from galvanized steel conforming to ASTM A653.
 - 1. Type:
 - a. 18 ga. and lighter: Grade A, 33,000 psi, or as shown on drawings.
 - b. 16 ga. and heavier: Grade D, 50,000 psi, or as shown on drawings.
 - 2. Components:
 - a. Conform to following general requirements for items specified herein:
 - 1). Framing: Conform to ASTM A653.
 - 2). Clips, angles, and accessories: ASTM A36.
 - 3). Welding electrodes: ASTM D1.1.

- C. Interior Wall Structural Framing Members: C-shaped, depth and thickness to match existing or as required by the design documents, by required widths and lengths selected for span and loads encountered from manufacturer's design tables and approved shop drawings. Provide same gage material for steel floor and ceiling runners, unless otherwise noted.

- D. Exterior wall structural framing members: G-60 rated galvanized per ASTM A525, C-shaped, depth and thickness to match existing or as required by the design documents, by required widths and lengths selected for span and loads encountered from manufacturer's design tables and approved shop drawings. Provide same gage for floor and ceiling runners, unless otherwise noted.

- E. Runners (tracks), bracing, gussets, and cups: Same gage as framing members.

2.2 FASTENERS

- A. **Stud to Stud:** For fastening light gage metal members to each other: 3/8-inch pan head screws, non-corrosive, self-tapping, in sizes (#12, #10, #8 or #6) quantities and spacing recommended by framing manufacturer for applications indicated, or as shown on drawings. Size, quantity and spacing of fasteners shall not be less than the existing.
- B. **Metal decking:** For fastening light gage metal framing to a corrugated metal deck: 3/8-inch pan head screws, non-corrosive, self-tapping, in sizes (#12, #10, #8 or #6) quantities and spacing recommended by framing manufacturer for applications indicated, or as shown on drawings. Size, quantity and spacing of fasteners shall not be less than the existing.
- C. **Concrete Surfaces:** For fastening light gage metal framing to concrete surfaces: Provide anchors as shown on drawings. Where not otherwise shown, provide powder actuated type fastener with the following allowable connection capacities: 200 lbs. shear and 200 lbs. withdraw force without. Size, quantity and spacing of fasteners shall not be less than the existing.
- D. **Structural Steel:** For fastening light gage metal framing to structural steel, clip angles and inserts: Welding or self-drilling screws. Welding shall be done using methods and electrode types in accordance with manufacturer's produce data. Mechanical fasteners shall be in accordance with the design drawings.
- E. Wire tying of light gage steel framing is not permitted.

2.3 ACCESSORY MEMBERS

- A. Bracing and bridging shall be same material and gauges as studs and runners.
- B. Steel clips, angles and concrete inserts to which light gage steel framing is attached shall comply with ASTM A36.

2.4 GALVANING REPAIR PAINT

- A. Galvacon, ZRC or accepted alternate.

PART 3 - EXECUTION

3.1 REPLACEMENT AND ERECTION OF METAL FRAMING

- A. **General - Wall framing:**
 - 1. Perform removal of rusted and/or deteriorated light gage metal framing which might be encountered behind exterior cladding during repair work. Perform replacement to match existing members sizes,

dimensions and fastenings, unless current code requirements are more stringent.

2. Where any portion of an existing framing member is deteriorated, the entire member must be removed and replaced, unless specifically indicated otherwise in the design documents.
3. Work shall include cleanup and removal of debris from site following each day's work.
4. If the condition of the existing structure to which the new metal framing is to be attached contains indications of distress, stop work and contact the Engineer immediately.

B. Interior and Exterior Wall Framing:

1. Studs:
 - a. Space studs as indicated on drawings, to match the existing installation. Do not exceed a spacing of 2-feet.
 - b. All studs shall contain square cut ends and shall fit snug to connected members. Field cutting of studs shall be by sawing or shearing. Torch cutting is not permitted.
 - c. Fit full length studs, aligned and plumbed, between upper and lower runners, ends in bearing, and attach both faces to runner flanges with pan head screws.
 - d. Provide jack studs or cripples where required to maintain uniform stud spacing.
 - e. Provide double studs at interior and exterior corner, expansion joints, panel terminations and as otherwise required by design requirements and manufacturer's product data.
2. Runners (Tracks): Attach runners to level surfaces with mechanical fasteners to match the existing design configuration. Do not exceed a spacing of 2-feet and within 3-inches of runner ends, unless shown otherwise on the drawings. Prior to installing runner, embed the runner in two lines of construction adhesive to the substrate.
3. Bracing and bridging:
 - a. Brace framing diagonally in accord with AISI reference standard without regard for facing materials and including tension straps both directions. Anchor to prevent uplift and brace back to structure.

- b. Provide bridging to comply with AISI reference standard and manufacturer's product data.
4. Splicing: Do not splice, cut or notch studs or other axially loaded or beam members.
5. Blocking: Provide intermediate runners and blocking to support edges of facing materials and built-in or attached construction.
6. Attachment:
 - a. Secure abutting and intersecting members using specified methods.
 - b. Weld to adjacent steel construction wherever possible.
 - c. Screw or bolt to dissimilar construction, providing isolation material between the dissimilar metallic elements.
 - d. Welds shall develop 1000 psi minimum strength to structural framing, 500 psi minimum to other lightweight framing components, in compliance with AWS Specifications.
 - e. Weld only 16 ga. and heavier framing members directly to structural framing; if welding to lighter material is necessary, weld lighter members to 16 ga. or heavier clips and weld clips to structural framing.
7. Painting: Clean and paint welds, bolts and abrasions of galvanized coating using Galvacon, ZRC or approved equivalent.
8. Alignment: Finished framing shall be in alignment, plumb and in the same plane, within tolerances specified for entire height and length of unbroken elevation.
9. Cutting for utilities: Do not remove, notch, cut or relocate load bearing studs or other structural members for utility installation or other cause without prior approval by Engineer.

3.2 APPLICATION

- A. Allowable tolerances for framing installation, unless other referenced sections require stricter tolerances:
 1. Variation from plumb: 1/4 inch in 10 ft. height, non-cumulative.
 2. Variation in horizontal squaring diagonals: 1/4 inch.

3. Variation in walls from tangent line (straightness): $1/4$ inch in 10 ft. non-cumulative.
 4. Variation in location of walls from dimension: $+ 1/4$ inch.
 5. Location of dimensioned openings: $+ 3/8$ inch.
 6. Variation in rough opening size: $+ 1/4$ inch - $1/8$ inch.
- B. Schedule: Provide stud size and gage as follows:
1. Noted on the drawings.

PART 4 - END OF SECTION 054050

SECTION 057150 – DECORATIVE ALUMINUM STAIRS

PART 1 - GENERAL

1.1 SUMMARY

- A. Section includes aluminum-framed decorative metal stairs.

1.2 ACTION SUBMITTALS

- A. Product Data: For metal stairs.
- B. Warranty information
- C. Shop Drawings: Include plans, elevations, sections, details, and attachments to other work.
- D. Engineering: Provide engineered drawings signed and sealed by an engineer registered in the state of Florida.

PART 2 - PRODUCTS

2.1 METAL STAIRS, GENERAL

- A. NAAMM Stair Standard: Comply with "Recommended Voluntary Minimum Standards for Fixed Metal Stairs" in NAAMM AMP 510, "Metal Stairs Manual," Architectural class, unless more stringent requirements are indicated.
- B. Engineering:
 - 1. All stair walking surfaces shall be designed for a live load of 100 pounds per square foot per the 2017 Florida Building Code.
 - 2. Stair dimensions shall be determined by the engineer. Dimensions on the drawings shall be used as a guideline. Field measurement is required.
 - 3. Handrails shall be designed per the 2017 Florida Building Code.
 - 4. All walking surfaces shall be slip resistant.
 - 5. Stair vertical loads shall be supported on the foundation. Attachment at the floors will be allowed for lateral loads only and must have a connection that allows movement vertically.

2.2 METALS

- A. Metal Surfaces, General: Provide materials with smooth, flat surfaces unless otherwise indicated. For components exposed to view in the completed Work, provide materials without seam marks, roller marks, rolled trade names, or blemishes.

- B. Aluminum Extrusions: **ASTM B 221**, Alloy 6063-T6.
- C. Aluminum Castings: ASTM B 26/B 26M, Alloy 443.0-F.

2.3 ABRASIVE NOSINGS

- A. Cast-Metal Units: Cast **aluminum**, with an integral abrasive, as-cast finish consisting of aluminum oxide, silicon carbide, or a combination of both. Fabricate units in lengths necessary to accurately fit openings or conditions.
- B. Extruded Units: **Aluminum** units with abrasive filler consisting of aluminum oxide, silicon carbide, or a combination of both, in an epoxy-resin binder. Fabricate units in lengths necessary to accurately fit openings or conditions.
 - 1. Provide ribbed units, with abrasive filler strips projecting **1/16 inch (1.5 mm)** above aluminum extrusion.
 - 2. Provide solid-abrasive-type units without ribs.
 - 3. Nosings: Square-back units, [**1-7/8 inches (48 mm)**] [**3 inches (75 mm)**] [**4 inches (100 mm)**] wide, without lip.

2.4 FASTENERS

- A. General: Provide stainless steel fasteners for all connections. Select fasteners for type, grade, and class required per engineering.
- B. Post-Installed Anchors: **chemical anchors** capable of sustaining, without failure, a load equal to six times the load imposed when installed in unit masonry and four times the load imposed when installed in concrete, as determined by testing according to ASTM E 488/E 488M, conducted by a qualified independent testing agency.

2.5 MISCELLANEOUS MATERIALS

- A. Universal Shop Primer: Fast-curing, lead- and chromate-free, universal modified-alkyd primer complying with MPI#79 and compatible with topcoat.
- B. Shop Primer for Galvanized Steel: Primer formulated for exterior use over zinc-coated metal and compatible with finish paint systems indicated.
- C. Galvanizing Repair Paint: High-zinc-dust-content paint complying with SSPC-Paint 20 and compatible with paints specified to be used over it.
- D. Bituminous Paint: Cold-applied asphalt emulsion complying with ASTM D 1187/D 1187M.

2.6 PRECAST CONCRETE TREADS ??

- A. Concrete Materials and Properties: Comply with requirements in Section 033000 "Cast-in-Place Concrete" for normal-weight, ready-mixed concrete with a minimum 28-day compressive strength of 5000 psi and a total air content of not less than 4 percent or more than 6 percent.
- B. Reinforcement: Galvanized, welded wire reinforcement, 2 by 2 inches by 0.062-inch diameter wire; comply with ASTM A 185/A 185M and ASTM A 82/A 82M, except for minimum wire size.

2.7 FABRICATION, GENERAL

- A. Provide complete stair assemblies, including metal framing, hangers, struts, clips, brackets, bearing plates, and other components necessary to support and anchor stairs and platforms on supporting structure.
 - 1. Join components by welding unless otherwise indicated.
 - 2. Use connections that maintain structural value of joined pieces.
- B. Cut, drill, and punch metals cleanly and accurately. Remove burrs and ease edges to a radius of approximately 1/32 inch unless otherwise indicated. Remove sharp or rough areas on exposed surfaces.
- C. Form bent-metal corners to smallest radius possible without causing grain separation or otherwise impairing work.
- D. Weld connections to comply with the following:
 - 1. Use materials and methods that minimize distortion and develop strength and corrosion resistance of base metals.
 - 2. Obtain fusion without undercut or overlap.
 - 3. Remove welding flux immediately.
 - 4. Weld exposed corners and seams continuously unless otherwise indicated.
 - 5. At exposed connections, finish exposed welds to comply with NOMMA's "Voluntary Joint Finish Standards" for Type 1 welds: no evidence of a welded joint.
- E. Form exposed connections with hairline joints, flush and smooth, using concealed fasteners where possible. Locate joints where least conspicuous.

2.8 ALUMINUM-FRAMED STAIRS

- A. Stair Framing:
 - 1. Fabricate stringers of aluminum **plates, channels, or tubes**.
 - a. Provide closures for exposed ends of stringers.

2. Construct platforms of aluminum **channel or tube** headers and miscellaneous framing members as indicated.
3. Weld or bolt all connections per engineering. **If using bolts, fabricate and join so bolts are not exposed on finished surfaces.**

B. Subtreads, Risers, and Subplatforms:

1. Fabricate subtreads and subplatforms of aluminum.
2. Form subtreads, risers, and subplatforms to configurations indicated in engineering.

2.9 STAIR RAILINGS

- A. Comply with applicable requirements in Section 057300 "Decorative Metal Railings."

2.10 FINISHES

- A. All metal shall be Kynar coated.

PART 3 - EXECUTION

3.1 INSTALLATION, GENERAL

- A. Cutting, Fitting, and Placement: Field cutting or drilling will require re-coating of altered member. Set units accurately in location, alignment, and elevation, measured from established lines and levels and free of rack.
- B. Install metal stairs by bolting to foundation for vertical loads and bolting to the building for lateral loads only.
- C. Fit exposed connections accurately together to form hairline joints.
- D. Field Welding: Field welding is not allowed.
- E. Install precast concrete treads with adhesive supplied by manufacturer.

3.2 ADJUSTING AND CLEANING

- A. Touchup Painting: ?? Immediately after erection, clean field welds, bolted connections, and abraded areas of shop paint, and paint exposed areas with same material as used for shop painting to comply with SSPC-PA 1 for touching up shop-painted surfaces.

END OF SECTION 057100

SECTION 057300 - DECORATIVE METAL RAILINGS

PART 1 - GENERAL

1.1 RELATED DOCUMENTS

- A. Drawings and general provisions of the Contract, including General and Supplementary Conditions and Division 01 Specification Sections, apply to this Section.

1.2 SUMMARY

- A. Section Includes:
 - 1. Aluminum decorative railings with stainless steel wire-rope guard infill.

1.3 DEFINITIONS

- A. Railings: Guards, handrails, and similar devices used for protection of occupants at open-sided floor areas and for pedestrian guidance and support, visual separation, or wall protection.

1.4 COORDINATION AND SCHEDULING

- A. Coordinate selection of shop primers with topcoats to be applied over them. Comply with coating manufacturers' written instructions to ensure that shop primers and topcoats are compatible.
- B. Coordinate installation of anchorages for railings. Furnish setting drawings, templates, and directions for installing anchorages, including sleeves, concrete inserts, anchor bolts, and items with integral anchors, that are to be embedded in concrete or masonry. Deliver items to Project site in time for installation.
- C. Schedule installation so wall attachments are made only to completed walls. Do not support railings temporarily by any means that do not meet structural performance requirements.

1.5 PREINSTALLATION MEETINGS

- A. Preinstallation Conference: Conduct conference at Project site.

1.6 ACTION SUBMITTALS

- A. Product Data: For the following:
 - 1. Manufacturer's product lines of railings assembled from standard components.
 - 2. Grout, anchoring cement, and coating products.

- B. Shop Drawings: Include plans, elevations, sections, and attachment details.
- C. Samples for Initial Selection: For products involving selection of color, texture, or design, including mechanical finishes.
- D. Delegated-Design Submittal: For installed products indicated to comply with performance requirements and design criteria, including analysis data signed and sealed by the qualified professional engineer responsible for their preparation.

1.7 INFORMATIONAL SUBMITTALS

- A. Qualification Data: For professional engineer or testing agency.
- B. Welding, fabrication, and coating certificates.
- C. Product Test Reports: Based on evaluation of comprehensive tests performed by a qualified testing agency, according to ASTM E 894 and ASTM E 935.
- D. Evaluation Reports: For post-installed anchors, from ICC-ES.

1.8 QUALITY ASSURANCE

- A. Welding Qualifications: Qualify procedures and personnel according to the following:
 - 1. AWS D1.2/D1.2M, "Structural Welding Code - Aluminum."
- B. Mockups: Build mockups to verify selections made under Sample submittals, to demonstrate aesthetic effects, and to set quality standards for fabrication and installation.
 - 1. Build mockups for each form and finish of railing consisting of two posts, top rail, infill area, and anchorage system components that are full height and are not less than 24 inches in length.
 - 2. Subject to compliance with requirements, approved mockups may become part of the completed Work if undisturbed at time of Substantial Completion.

1.9 FIELD CONDITIONS

- A. Field Measurements: Verify actual locations of walls and other construction contiguous with railings by field measurements before fabrication and indicate measurements on Shop Drawings.

PART 2 - PRODUCTS

2.1 MANUFACTURERS

- A. Aluminum Decorative Railings:

1. Aerotech Aluminum, Inc.; Sanford, Florida (386)322-3356 www.aerotecaluminum.com or approved equal.

B. Source Limitations: Obtain each type of railing from single source from single manufacturer.

C. Product Options: Information on Drawings and in Specifications establishes requirements for system's aesthetic effects and performance characteristics. Aesthetic effects are indicated by dimensions, arrangements, alignment, and profiles of components and assemblies as they relate to sightlines, to one another, and to adjoining construction. Performance characteristics are indicated by criteria subject to verification by one or more methods, including structural analysis, preconstruction testing, field testing, and in-service performance.

1. Do not modify intended aesthetic effects, as judged solely by Architect, except with Architect's approval. If modifications are proposed, submit comprehensive explanatory data to Architect for review.

2.2 PERFORMANCE REQUIREMENTS

A. Delegated Design: Engage a qualified professional engineer, with a current PE license for the State of Florida to design railings, including attachment to building construction.

B. General: In engineering railings to withstand structural loads indicated, determine allowable design working stresses of railing materials based on the following:

1. Aluminum: The lesser of minimum yield strength divided by 1.65 or minimum ultimate tensile strength divided by 1.95.

C. Structural Performance: Railings, including attachment to building construction, shall withstand the effects of gravity loads and the following loads and stresses within limits and under conditions indicated:

1. Handrails and Top Rails of Guards:
 - a. Uniform load of 50 lb/ft. applied in any direction.
 - b. Concentrated load of 200 lb applied in any direction.
 - c. Uniform and concentrated loads need not be assumed to act concurrently.
2. Infill of Guards:
 - a. Concentrated load of 50 lb applied horizontally on an area of 1 sq. ft.
 - b. Infill load and other loads need not be assumed to act concurrently.

D. Thermal Movements: Allow for thermal movements from ambient and surface temperature changes acting on exterior railings by preventing buckling, opening of joints, overstressing of components, failure of connections, and other detrimental effects.

1. Temperature Change: 120 deg F, ambient; 180 deg F, material surfaces.

2.3 METALS, GENERAL

A. Metal Surfaces, General: Provide materials with smooth surfaces, without seam marks, roller marks, rolled trade names, stains, discolorations, or blemishes.

- B. Brackets, Flanges, and Anchors: Same metal and finish as supported rails unless otherwise indicated.
 - 1.
 - 2. Provide extruded-aluminum brackets with interlocking pieces that conceal anchorage. Locate set screws on bottom of bracket.

2.4 ALUMINUM

- A. Aluminum, General: Provide alloy and temper recommended by aluminum producer and finisher for type of use and finish indicated, and with strength and durability properties for each aluminum form required not less than that of alloy and temper designated below.
- B. Extruded Bars and Shapes, Including Extruded Tubing: ASTM B 221, Alloy 6063-T5/T52.
- C. Extruded Structural Pipe and Round Tubing: ASTM B 429/B 429M, Alloy 6063-T6.
 - 1. Provide Standard Weight (Schedule 40) pipe unless otherwise indicated.
- D. Drawn Seamless Tubing: ASTM B 210, Alloy 6063-T832.
- E. Plate and Sheet: ASTM B 209, Alloy 5005-H32 or Alloy 6061-T6.
- F. Die and Hand Forgings: ASTM B 247, Alloy 6061-T6.
- G. Castings: ASTM B 26/B 26M, Alloy A356.0-T6.

2.5 STAINLESS STEEL

- A. Wire Rope and Fittings:
 - 1. Wire Rope: 1-by-19 wire rope made from wire complying with ASTM A 492, Type 316.
 - 2. Wire-Rope Fittings: Connectors of types indicated, fabricated from stainless steel, and with capability to sustain, without failure, a load equal to minimum breaking strength of wire rope with which they are used.

2.6 FASTENERS

- A. Fastener Materials: Unless otherwise indicated, provide the following:
 - 1. Aluminum Components: Type 316 stainless-steel fasteners.
 - 2. Stainless-Steel Components: Type 316 stainless-steel fasteners.
 - 3. Dissimilar Metals: Type 316 stainless-steel fasteners.
- B. Fasteners for Anchoring to Other Construction: Select fasteners of type, grade, and class required to produce connections suitable for anchoring railings to other types of construction indicated and capable of withstanding design loads.
- C. Provide concealed fasteners for interconnecting railing components and for attaching railings to other work unless otherwise indicated.

1. Provide tamper-resistant flat-head machine screws for exposed fasteners unless otherwise indicated.

D. Post-Installed Anchors: Fastener systems with working capacity greater than or equal to the design load, according to an evaluation report acceptable to authorities having jurisdiction, based on ICC-ES AC193 or ICC-ES AC308.

2.7 MISCELLANEOUS MATERIALS

A. Welding Rods and Bare Electrodes: Select according to AWS specifications for metal alloy welded.

1. For aluminum railings, provide type and alloy as recommended by producer of metal to be welded and as required for color match, strength, and compatibility in fabricated items.

B. Non-shrink, Nonmetallic Grout: Factory-packaged, non-staining, noncorrosive, nongaseous grout complying with ASTM C 1107/C 1107M. Provide grout specifically recommended by manufacturer for interior and exterior applications.

C. Anchoring Cement: Factory-packaged, non-shrink, non-staining, hydraulic-controlled expansion cement formulation for mixing with water at Project site to create pourable anchoring, patching, and grouting compound.

1. Water-Resistant Product: At exterior locations provide formulation that is resistant to erosion from water exposure without needing protection by a sealer or waterproof coating and that is recommended by manufacturer for exterior use.

2.8 FABRICATION

A. General: Fabricate railings to comply with requirements indicated for design, dimensions, member sizes and spacing, details, finish, and anchorage, but not less than that required to support structural loads.

B. Assemble railings in the shop to greatest extent possible to minimize field splicing and assembly. Disassemble units only as necessary for shipping and handling limitations. Clearly mark units for reassembly and coordinated installation. Use connections that maintain structural value of joined pieces.

C. Cut, drill, and punch metals cleanly and accurately. Remove burrs and ease edges to a radius of approximately 1/32 inch unless otherwise indicated. Remove sharp or rough areas on exposed surfaces.

D. Form work true to line and level with accurate angles and surfaces.

E. Fabricate connections that will be exposed to weather in a manner to exclude water. Provide weep holes where water may accumulate. Locate weep holes in inconspicuous locations.

F. Cut, reinforce, drill, and tap as indicated to receive finish hardware, screws, and similar items.

- G. Connections: Fabricate railings with welded connections unless otherwise indicated.
- H. Welded Connections: Cope components at connections to provide close fit, or use fittings designed for this purpose. Weld all around at connections, including at fittings.
 - 1. Use materials and methods that minimize distortion and develop strength and corrosion resistance of base metals.
 - 2. Obtain fusion without undercut or overlap.
 - 3. Remove flux immediately.
 - 4. At exposed connections, finish exposed welds to comply with NOMMA's "Voluntary Joint Finish Standards" for Type 1 welds; no evidence of a welded joint.
- I. Welded Connections for Aluminum Pipe: Fabricate railings to interconnect members with concealed internal welds that eliminate surface grinding, using manufacturer's standard system of sleeve and socket fittings.
- J. Mechanical Connections: Connect members with concealed mechanical fasteners and fittings. Fabricate members and fittings to produce flush, smooth, rigid, hairline joints.
 - 1. Fabricate splice joints for field connection using an epoxy structural adhesive if this is manufacturer's standard splicing method.
- K. Form changes in direction as follows:
 - 1. By bending to smallest radius that will not result in distortion of railing member.
- L. Bend members in jigs to produce uniform curvature for each configuration required; maintain cross section of member throughout entire bend without buckling, twisting, cracking, or otherwise deforming exposed surfaces of components.
- M. Close exposed ends of hollow railing members with prefabricated end fittings.
- N. Provide wall returns at ends of wall-mounted handrails unless otherwise indicated. Close ends of returns, unless clearance between end of rail and wall is 1/4 inch or less.
- O. Provide inserts and other anchorage devices for connecting railings to concrete or masonry work. Fabricate anchorage devices capable of withstanding loads imposed by railings. Coordinate anchorage devices with supporting structure.

2.9 GENERAL FINISH REQUIREMENTS

- A. Comply with NAAMM's "Metal Finishes Manual for Architectural and Metal Products" recommendations for applying and designating finishes. Contractor to provide coating manufacturer's qualifications and certificates with submittals prior to fabrication.
- B. Protect mechanical finishes on exposed surfaces from damage by applying a strippable, temporary protective covering before shipment.
- C. Appearance of Finished Work: Noticeable variations in same piece are not acceptable. Variations in appearance of abutting or adjacent pieces are acceptable if they are within one-half of the range of approved Samples. Variations in appearance of other components are

acceptable if they are within the range of approved Samples and are assembled or installed to minimize contrast.

- D. Provide exposed fasteners with finish matching appearance, including color and texture, of railings.

2.10 ALUMINUM FINISHES

- A. High-Performance Organic Finish: Three-coat fluoropolymer finish (Kynar) complying with AAMA 2605 and containing not less than 70 percent PVDF resin by weight in both color coat and clear topcoat. Prepare, pretreat, and apply coating to exposed metal surfaces to comply with coating and resin manufacturers' written instructions. Contractor to provide minimum 10 year finish warranty against any and all coating defects, including but not limited to, chipping, peeling, fading, and oxidation.
 - 1. Color and Gloss: As selected by Architect from manufacturer's full range.

PART 3 - EXECUTION

3.1 INSTALLATION, GENERAL

- A. Fit exposed connections together to form tight, hairline joints.
- B. Perform cutting, drilling, and fitting required for installing railings. Set railings accurately in location, alignment, and elevation; measured from established lines and levels and free of rack.
 - 1. Do not weld, cut, or abrade surfaces of railing components that have been coated or finished after fabrication and that are intended for field connection by mechanical or other means without further cutting or fitting.
 - 2. Set posts plumb within a tolerance of 1/16 inch in 3 feet.
 - 3. Align rails so variations from level for horizontal members and variations from parallel with rake of steps and ramps for sloping members do not exceed 1/4 inch in 12 feet.
- C. Control of Corrosion: Prevent galvanic action and other forms of corrosion by insulating metals and other materials from direct contact with incompatible materials.
 - 1. Coat concealed surfaces of aluminum and copper alloys that will be in contact with grout, concrete, masonry, wood, or dissimilar metals, with a heavy coat of bituminous paint.
- D. Adjust railings before anchoring to ensure matching alignment at abutting joints.
- E. Fastening to In-Place Construction: Use anchorage devices and fasteners where necessary for securing railings and for properly transferring loads to in-place construction.

3.2 RAILING CONNECTIONS

- A. Non-welded Connections: Use mechanical or adhesive joints for permanently connecting railing components. Use wood blocks and padding to prevent damage to railing members and fittings. Seal recessed holes of exposed locking screws using plastic cement filler colored to match finish of railings.
- B. Welded Connections: Use fully welded joints for permanently connecting railing components. Comply with requirements for welded connections in "Fabrication" Article whether welding is performed in the shop or in the field.
- C. Expansion Joints: Install expansion joints at locations indicated but not farther apart than required to accommodate thermal movement. Provide slip-joint internal sleeve extending 2 inches beyond joint on either side, fasten internal sleeve securely to one side, and locate joint within 6 inches of post.

3.3 ANCHORING POSTS

- A. Anchor railing posts to concrete and masonry with flanges connected to railing posts and anchored to concrete floor with anchors and bolts.
- B. Anchor posts to metal surfaces with flanges, angle type, or floor type as required by conditions, connected to posts and to metal supporting members as follows:
 - 1. For aluminum railings, attach posts as indicated using fittings designed and engineered for this purpose.

3.4 FIELD QUALITY CONTROL

- A. AOR/EOR will randomly select completed railing assemblies for testing that are representative of different railing designs and conditions in the completed Work. Test railings according to ASTM E 894 and ASTM E 935 for compliance with performance requirements.
- B. Remove and replace railings where test results indicate that they do not comply with specified requirements unless they can be repaired in a manner satisfactory to Architect and comply with specified requirements.
- C. Perform additional testing and inspecting, at Contractor's expense, to determine compliance of replaced or additional work with specified requirements.

3.5 CLEANING

- A. Clean aluminum and stainless steel by washing thoroughly with clean water and soap, rinsing with clean water, and wiping dry. Also follow manufacturers' other conditions for warranties.

3.6 PROTECTION

- A. Protect finishes of railings from damage during construction period with temporary protective coverings approved by railing manufacturer. Remove protective coverings at time of Substantial Completion.
- B. Restore finishes damaged during installation and construction period so no evidence remains of correction work. Return items that cannot be refinished in the field to the shop; make required alterations and refinish entire unit, or provide new units.

END OF SECTION 057300

SECTION 061010 - WOOD FRAMING AND SHEATHING REPAIRS

PART 1 - GENERAL

1.1 SUMMARY

- A. Provide wood framing and sheathing repair to structural and non-structural components when damage to the structure is less than Substantial Structural Damage as defined by the most recent edition of the Florida Existing Building Code. Generally, repairs required by damage to vertical load carrying elements shall constitute less than 30% of the total building vertical load carrying system and/or repairs required by damage to the lateral load carrying system shall constitute less than 20% of the lateral load carrying building system at each floor. This specification is not applicable for Substantial Structural Damage.

1.2 PERMITS, FEES, AND INSURANCE:

- A. The Owner and/or their contractor shall coordinate all approvals through the Association Board and the Architectural Review Board, as applicable. Submit product data including manufacturer's installation instructions for all products not specifically identified herein.
- B. Contractor shall secure all necessary permits prior to commencement of the work.
- C. Contractor shall procure and maintain in force until the completion of work the following insurances in the amounts required by the Owner and the Association Board: general liability insurance, employer's liability insurance, automobile insurance and worker compensation. Contractor shall ensure that current insurance certificates are on file with the management company.

1.3 SUBMITTALS

- A. Quantity: Three copies for each product
- B. Submit product data including manufacturer's installation instructions for all products not specifically identified herein.

1.4 WARRANTY

- A. Manufacture: Provide manufacturer's standard warranty.
- B. Applicator: Provide all labor and materials required to repair work that fails to perform for **five (5) years** following the date of substantial completion.

1.5 QUALITY ASSURANCE

- A. Maintain one copy of each referenced document covering installation requirements on site.

- B. Comply with governing codes and regulations. Provide products of acceptable manufacturers, approved by the local building code agency, and have been in satisfactory use in similar service for no less than three years. Use experienced installers.
- C. All temporary utility services, including toilet facilities, are to be obtained and paid for by the contractors performing the work described herein.

PART 2 - PRODUCTS

2.1 MATERIALS

- A. Dimensional Lumber:
 - 1. General: Framing lumber shall comply with the latest edition of the grading rules of the Western Wood Products Association (WWPA). All sawn lumber shall be stamped with the grade mark of a lumber grading agency accredited by the American Lumber Standard Committee (ALSC).
 - 2. Wall studs: Spruce Pine Fir, No. 2, standard, or stud grade lumber
 - 3. Headers, beams, joists, top plates: Southern Yellow Pine, No. 2 or better, u.o.n.
 - 4. Sole plates: Southern Pine, No. 2 or better. Preservative treated when in contact with concrete.
- B. Wall Sheathing: APA CDX rated plywood bearing the stamp of an approved ratings agency, of thickness and fire rating to match the existing. Oriented Strand Board (OSB) is not an acceptable substitute. Specific gravity shall be a minimum of 0.42
- C. Pre-engineered wood I joists (TJI Type): All I joists requiring replacement shall be examined by the engineer to determine the material requirements for replacement.
- D. Pre-engineered wood trusses and joists: All pre-engineered trusses or joists requiring replacement shall be examined by the engineer to determine the material requirements for replacement.
- E. Laminated Beams: All laminated beams requiring replacement shall be examined by the engineer to determine the material requirements for replacement.
- F. All wood exposed to the elements or in contact with concrete shall be preservative treated in accordance with the applicable requirements of the AWPA.
- G. Fasteners:
 - 1. General: Type, size, length, spacing, and configuration to match existing conditions or current building code requirements, which ever is more stringent. Refer to 2014 FBC Fastener Schedule for fastener code requirements.
 - 2. Exterior walls: ASTM A135 Class D galvanized or 300 Series Stainless Steel. DO NOT USE STAINLESS STEEL TO FASTEN GALVANIZED COMPONENTS.
 - 3. Interior walls: Common steel
 - 4. Connectors: As required, by Simpson Strong-Tie or approved equivalent. USE LIKE MATERIAL FASTENERS TO SECURE CONNECTORS.

5. Connectors to ACQ or CCA Preservative treated wood: ASTM A653 Class G-185 or 300 Series Stainless Steel. DO NOT USE STAINLESS STEEL TO FASTEN GALVANIZED COMPONENTS. DO NOT USE ALUMINUM CONNECTORS.
6. Fasteners to ACQ or CCA Preservative treated wood: ASTM A135 Class D galvanized or 300 Series Stainless Steel. DO NOT USE STAINLESS STEEL TO FASTEN GALVANIZED COMPONENTS. DO NOT USE ALUMINUM FASTENERS.
7. Fasteners to be exposed: Series 300 stainless steel. Ensure that connected components are galvanically similar.
8. Wood Adhesive: Liquid Nails Multi-Purpose Wood Projects Construction Adhesive or approved equivalent.
9. Concrete Anchor Epoxy: Hilti HIT HY 150 Adhesive or approved equivalent.

H. Insulation:

1. Type:
 - a. Owens Corning Foamular Extruded Polystyrene Insulation or approved equivalent rigid closed-cell foam insulation board with R-value > 5.0 per inch of material.
2. Insulating Value: The greatest of the following:
 - a. R-13
 - b. Requirements of current code
 - c. R-value of existing wall insulation, in its new condition.

2.2 STORAGE AND HANDLING

- A. Store only acceptable project materials on-site as directed and approved by Owner/Owners Representative.
- B. Store wood materials off grade and protect from the elements.
- C. Deliver, handle, and store materials in accordance with manufacturer's instructions.
- D. Restrict storage to materials and related equipment.
- E. Keep all containers tightly closed when not in use.
- F. Remove empty containers, wrappings, and similar materials from building and grounds at end of each day's work.

PART 3 - EXECUTION

3.1 Wood framing replacement

- A. Provide shoring, as required to support the full load imposed on the wood members to be removed. Shoring shall be positioned at the panel points of truss type members.
- B. Remove deteriorated or stained wood material as required by the engineer.

- C. If any portion of a dimensional lumber framing component contains deterioration or staining deemed to require repair by the engineer, the entire component shall be removed and replaced, unless otherwise noted on applicable drawings or approved by the engineer.
- D. Replace wall studs, top plates, and window or door headers with wood size, dimension, and grade in kind unless current code requirements are more stringent.
- E. Replacement of wood framing and fastening shall comply with all applicable requirements of the local building code.
- F. Provide uplift strapping or tie down system per the original project documents, as applicable. Re-secure existing wind uplift strapping where applicable. If uplift strapping is deteriorated, replace in kind or with equal approved by the owner's representative.
- G. If uplift strapping is not detailed or provided at the area observed, provide strapping and anchorage as required to achieve 200 plf uplift capacity. The configuration of the uplift resisting load path shall be continuous from the foundation to the truss tails, or to the vertical extent of the repair area exposed.
- H. Install connectors, straps, tie downs, and anchors in accordance with the manufacturer's instructions.
- I. Notching of wall studs for exist utility penetrations shall not exceed 25% of stud width. Bored holes shall be less than 40% of the stud width and shall be located in the center of the stud.
- J. Double top plates shall be provided at the top of all wall framing. Top plate splices shall have a minimum stagger equal to the stud spacing. Corners of top plates shall also be staggered.
- K. Rim Boards, present between floors that are fully supported by the wall below, shall be replaced in kind. Where composite, stagger the splice joints of each board in the composite assembly by a minimum of 24-inches.
- L. Sole plates shall be secured to the foundation with ½" diameter threaded rod drilled and epoxied into the existing foundation. Anchors shall be located within 4-inches of the end of a sole plate board and spaced at a maximum of 4-feet o.c. along its length.
- M. Install epoxy in accordance with the manufacturer's instructions.
- N. Notify the engineer if conditions exist which require repair that are not adequately defined in the project documents.

3.2 WOOD SHEATHING REPLACEMENT

- A. Remove deteriorated or stained wood material as required by the engineer.
- B. Contractor shall verify existing thickness and fire rating of existing sheathing.
- C. Replace sheathing material with new to match the existing thickness. Lay up with face grain parallel to supports. Stagger all joints.

- D. Fasten sheathing to match fastener size, number, and configuration in accordance with the local building code requirements, unless the existing configuration is more stringent, or unless otherwise noted on the project documents.

3.3 LATERAL STRUCTURAL FRAMING

- A. Contact the engineer if damage to laminated wood, pre-engineered truss or TJI type wood members is encountered. Repair of such members will require engineering evaluation and replacement documents that are specific to the particular location.
- B. Do not cut truss members.

3.4 WOOD TRIM REPLACEMENT

- A. Remove deteriorated or stained wood material as required.
- B. Replace trim material with new to match the existing type and size.
- C. Miter all joints and splices.
- D. Fasten trim in accordance with the local building code requirements, unless the existing configuration is more stringent, or unless otherwise noted on the project documents.

3.5 INTERIOR FINISHES

- A. Remove and replace interior gypsum wall board and/or baseboards, crown molding, and trim as required due to moisture damage or impact from repair activities.
- B. Removal of suspect mold contaminated surface areas shall be completed in strict compliance with the Institute of Inspection Cleaning and Restoration Certification (IICRC) Standard Reference Guide S-520 guidelines and applicable OSHA requirements.
- C. Any repair areas which contain visual suspect microbial growth (VSMG) or evidence of potential VSMG whose removal may allow airborne spore entry into a finished space shall be contained and removed in accordance with the recommendations of the Institute of Inspection Cleaning and Restoration Certification (IICRC) S-520, *Standard and Reference Guide for Professional Mold Remediation*. The contractor performing the work shall be certified by the IICRC and fully equipped to perform remediation procedures per the referenced guide.
- D. Air sample clearance testing shall be performed following the completion of repairs within the contained repair area to ensure that air-born microbial organisms are within acceptable levels as established by the Indoor Air Quality Association (IAQA) and as compared to exterior baseline levels.
- E. Paint new wall surfaces to match the existing.
- F. Fasten trim in accordance with the local building code requirements, unless the existing configuration is more stringent, or unless otherwise noted on the project documents.

3.6 INSULATION

- A. Remove wet, deteriorated or missing building insulation that is encountered during repair work.
- B. Replacement insulation in exterior walls shall be completed with multiple laminations of rigid foam insulation to achieve a minimum thickness of 3-inches or as required to achieve the specified R-value. Installation shall be in accordance with the manufacturer's specifications.

3.7 CLEAN UP

- A. Remove all debris from site on a daily basis.
- B. Remove VSM containing debris per IICRC requirements.
- C. All surfaces shall be swept clean daily.
- D. All ground surfaces shall be swept with a magnetic broom daily.
- E. Remove all unused material and debris from site upon the completion of work.
- F. Replace all damaged plantings, turf, and other vegetation.

END OF SECTION

SECTION 071800 - TRAFFIC COATINGS

PART 1 - GENERAL

1.1 RELATED DOCUMENTS

- A. Drawings and general provisions of the Contract, including General and Supplementary Conditions and Division 01 Specification Sections, apply to this Section.

1.2 SUMMARY

- A. Section includes traffic coatings for the following applications:
 - 1. Pedestrian traffic.

1.3 PREINSTALLATION MEETINGS

- A. Preinstallation Conference: Conduct conference at Project site.

1.4 ACTION SUBMITTALS

- A. Product Data: For each type of product, including installation instructions.
- B. Samples for Initial Selection: For each type of exposed finish.
- C. Samples for Verification: For each type of exposed finish, prepared on rigid backing.
 - 1. Provide stepped Samples on backing to illustrate buildup of traffic coatings.

1.5 INFORMATIONAL SUBMITTALS

- A. Qualification Data: For Installer.
- B. Product Certificates: For each type of traffic coating.
- C. Field quality-control reports.
- D. Sample Warranty: For special warranty.

1.6 CLOSEOUT SUBMITTALS

- A. Maintenance Data: For traffic coatings to include in maintenance manuals.

1.7 QUALITY ASSURANCE

- A. Installer Qualifications: An authorized representative who is trained and approved by manufacturer.
- B. Mockups: Build mockups to set quality standards for materials and execution.
 - 1. Build mockup for each traffic coating and substrate to receive traffic coatings.
 - 2. Size: 200 sq. ft. of each substrate to demonstrate surface preparation, joint and crack treatment, thickness, texture, color, and standard of workmanship.
 - 3. Approval of mockups does not constitute approval of deviations from the Contract Documents contained in mockups unless Architect specifically approves such deviations in writing.
 - 4. Subject to compliance with requirements, approved mockups may become part of the completed Work if undisturbed at time of Substantial Completion.

1.8 FIELD CONDITIONS

- A. Environmental Limitations: Apply traffic coatings within the range of ambient and substrate temperatures recommended in writing by manufacturer. Do not apply traffic coatings to damp or wet substrates, when temperatures are below 40 deg F, when relative humidity exceeds 85 percent, or when temperatures are less than 5 deg F above dew point.
 - 1. Do not apply traffic coatings in snow, rain, fog, or mist, or when such weather conditions are imminent during the application and curing period. Apply only when frost-free conditions occur throughout the depth of substrate.
- B. Do not install traffic coating until items that penetrate membrane have been installed.

1.9 WARRANTY

- A. Manufacturer's Warranty: Manufacturer agrees to repair or replace traffic coating that fails in materials or workmanship within specified warranty period.
 - 1. Failures include, but are not limited to, the following:
 - a. Adhesive or cohesive failures.
 - b. Abrasion or tearing failures.
 - c. Surface crazing or spalling.
 - d. Intrusion of water, oils, gasoline, grease, salt, deicer chemicals, or acids into deck substrate.
 - 2. Warranty Period: Five years from date of Substantial Completion.

PART 2 - PRODUCTS

2.1 MATERIALS, GENERAL

- A. Material Compatibility: Provide primers; base-, intermediate-, and topcoat; and accessory materials that are compatible with one another and with substrate under conditions of service and application, as demonstrated by manufacturer based on testing and field experience.
- B. Source Limitations:
 - 1. Obtain traffic coatings from single source from single manufacturer.
 - 2. Obtain primary traffic-coating materials, including primers, from traffic-coating manufacturer. Obtain accessory materials including aggregates, sheet flashings, joint sealants, and substrate repair materials of types and from sources recommended in writing by primary material manufacturer.

2.2 TRAFFIC COATING

- A. Traffic Coating: Manufacturer's standard, traffic-bearing, seamless, high-solids-content, cold liquid-applied, elastomeric, waterproofing membrane system with integral wearing surface for pedestrian traffic; according to ASTM C 957.
 - 1. Neogard Decorative Peda-Gard
- B. Primer: Liquid solvent-borne primer recommended for substrate and conditions by traffic-coating manufacturer.
 - 1. Material: Urethane.
- C. Preparatory and Base Coats: Polyurethane.
 - 1. Thicknesses: Minimum dry or wet film thickness as recommended in writing by manufacturer for substrate and service conditions indicated.
- D. Intermediate Coat: Polyurethane.
 - 1. Thicknesses: Minimum dry or wet film thickness as recommended in writing by manufacturer for substrate and service conditions indicated, measured excluding aggregate.
 - 2. Aggregate Content: As recommended in writing by traffic-coating manufacturer for substrate and service conditions indicated to refusal.
- E. Topcoat: Aliphatic urethane.
 - 1. Thicknesses: Minimum dry or wet film thickness as recommended in writing by manufacturer for substrate and service conditions indicated, measured excluding aggregate.
 - 2. Aggregate Content: As recommended in writing by traffic-coating manufacturer for substrate and service conditions indicated as required to achieve slip-resistant finish to refusal.
 - 3. Color: As selected by Architect from manufacturer's full range.

- F. Aggregate: Manufacturer's standard aggregate for each use indicated of particle sizes, shape, and minimum hardness recommended in writing by traffic-coating manufacturer.

2.3 ACCESSORY MATERIALS

- A. Joint Sealants: Compatible with traffic coating, and as specified in Section 079200 "Joint Sealants." ASTM C 920.
- B. Sheet Flashing: Nonstaining sheet material recommended in writing by traffic-coating manufacturer.
 - 1. Thickness: As required by manufacturer.
- C. Adhesive: Contact adhesive recommended in writing by traffic-coating manufacturer.
- D. Reinforcing Strip: Fiberglass mesh recommended in writing by traffic-coating manufacturer.

PART 3 - EXECUTION

3.1 EXAMINATION

- A. Examine substrates, areas, and conditions, with Installer present, for compliance with requirements for surface smoothness, surface moisture, and other conditions affecting performance of traffic-coating work.
- B. Verify that substrates are visibly dry and free of moisture.
 - 1. Test for moisture according to ASTM D 4263.
 - 2. Test for moisture content by measuring with an electronic moisture meter and/or method recommended in writing by traffic-coating manufacturer.
- C. Prepare written report, endorsed by Installer, listing conditions detrimental to performance of traffic-coating work.
- D. Proceed with installation only after substrate construction and penetrating work have been completed and unsatisfactory conditions have been corrected.
 - 1. Begin coating application only after minimum concrete-curing and -drying period recommended in writing by traffic-coating manufacturer has passed and after substrates are dry.
 - 2. Application of coating indicates acceptance of surfaces and conditions.

3.2 PREPARATION

- A. General: Before applying traffic coatings, clean and prepare substrates according to ASTM C 1127 and manufacturer's written instructions to produce clean, dust-free, dry substrate for traffic-coating application. Remove projections, fill voids, and seal joints if any, as recommended in writing by traffic-coating manufacturer.

- B. Schedule preparation work so dust and other contaminants from process do not fall on wet, newly coated surfaces.
- C. Mask adjoining surfaces not receiving traffic coatings to prevent overspray, spillage, leaking, and migration of coatings. Prevent traffic-coating materials from entering deck substrate penetrations and clogging weep holes and drains.
- D. Concrete Substrates: Mechanically abrade surface to a uniform profile acceptable to manufacturer, according to ASTM D 4259. Do not acid etch.
 - 1. Remove grease, oil, paints, and other penetrating contaminants from concrete.
 - 2. Remove concrete fins, ridges, and other projections.
 - 3. Remove laitance, glaze, efflorescence, curing compounds, concrete hardeners, form-release agents, and other incompatible materials that might affect coating adhesion.
 - 4. Remove remaining loose material to provide a sound surface, and clean surfaces according to ASTM D 4258.

3.3 TERMINATIONS AND PENETRATIONS

- A. Prepare vertical and horizontal surfaces at terminations and penetrations through traffic coatings and at expansion joints, drains, and sleeves according to ASTM C 1127 and manufacturer's written instructions.
- B. Provide sealant cants at penetrations and at reinforced and non-reinforced, deck-to-wall butt joints.
- C. Terminate edges of deck-to-deck expansion joints with preparatory base-coat strip.
- D. Install sheet flashings at deck-to-wall expansion and dynamic joints, and bond to deck and wall substrates according to manufacturer's written recommendations.

3.4 JOINT AND CRACK TREATMENT

- A. Prepare, treat, rout, and fill joints and cracks in substrates according to ASTM C 1127 and manufacturer's written recommendations. Before coating surfaces, remove dust and dirt from joints and cracks according to ASTM D 4258.
 - 1. Comply with recommendations in ASTM C 1193 for joint-sealant installation.
- B. Apply reinforcing strip in traffic-coating system where recommended in writing by traffic-coating manufacturer.

3.5 TRAFFIC-COATING APPLICATION

- A. Apply traffic coating according to ASTM C 1127 and manufacturer's written instructions.
- B. Apply number of coats of specified compositions for each type of traffic coating at locations as indicated on Drawings.

- C. Start traffic-coating application in presence of manufacturer's technical representative.
- D. Verify that wet film thickness of each coat complies with requirements every 100 sq. ft..
- E. Uniformly broadcast aggregate on coats specified to receive aggregate. Embed aggregate according to manufacturer's written instructions. After coat dries, sweep away excess aggregate.
- F. Apply traffic coatings to prepared wall terminations and vertical surfaces to height indicated; omit aggregate on vertical surfaces.
- G. Cure traffic coatings. Prevent contamination and damage during application and curing stages.

3.6 FIELD QUALITY CONTROL

- A. Testing Agency: Engage a qualified testing agency to perform the following field tests and inspections:
 - 1. Materials Testing:
 - a. Samples of material delivered to Project site shall be taken, identified, sealed, and certified in presence of Owner's Representative and Contractor.
 - b. Testing agency shall perform tests for characteristics specified, using applicable referenced testing procedures.
 - c. Testing agency shall verify thickness of coatings during traffic-coating application for each 600 sq. ft. of installed traffic coating or part thereof.
 - 2. Electronic Leak-Detection Testing:
 - a. Testing agency shall test each deck area indicated for testing on Drawings for leaks using an electronic leak-detection method that locates discontinuities in the traffic-coating membrane.
 - b. Testing agency shall perform tests on abutting or overlapping smaller areas as necessary to cover entire test area.
 - c. Testing agency shall create a conductive electronic field over the area of traffic coating to be tested and electronically determine locations of discontinuities or leaks, if any, in the traffic coating.
 - d. Testing agency shall provide survey report indicating locations of discontinuities, if any.
 - 3. If test results show traffic coating does not comply with requirements, remove and replace or repair the membrane as recommended in writing by traffic-coating manufacturer and make further repairs after retesting until traffic-coating installation passes.
- B. Final Traffic-Coating Inspection: Arrange for traffic-coating manufacturer's technical personnel to inspect membrane installation on completion.
 - 1. Notify Architect/Engineer or Owner 48 hours in advance of date and time of inspection.
- C. Additional testing and inspecting, at Contractor's expense, will be performed to determine compliance of replaced or additional work with specified requirements.
- D. Prepare test and inspection reports.

3.7 PROTECTING AND CLEANING

- A. Protect traffic coatings from damage and wear during remainder of construction period.
- B. Clean spillage and soiling from adjacent construction using cleaning agents and procedures recommended by manufacturer of affected construction.

END OF SECTION 071800

SECTION 076200 - FLASHING AND SHEET METAL

PART 1 - GENERAL

1.1 SUMMARY

- A. Provide flashing and sheet metal.

1.2 RELATED SECTIONS

- A. Section 075200: Modified Bitumen Roofing
- B. Section 079200: Joint Sealers

1.3 REFERENCES

- A. FBC: Florida Building Code, most recent addition
- B. ASTM B 209 - Standard Specification for Aluminum and Aluminum-Alloy Sheet and Plate.
- C. ASTM A 167 – Standard Specification for Stainless and Heat Resisting Chromium-Nickel Steel Plate, Sheet and Strip.
- D. Federal Specification – QQ-L-201, Lead Sheet.
- E. NRCA: National Roofing Contractors Association “NRCA Roofing and Waterproofing Manual”.
- F. SMACNA: Sheet Metal and Air Conditioning Contractors National Association, Inc.” SMACNA Architectural Sheet Metal Manual”.

1.4 SUBMITTALS

- A. Quantity: Three copies for each product
- B. Submit product data including manufacturer’s installation instructions for all products not specifically identified herein.

1.5 QUALITY ASSURANCE

- A. All temporary utility services, including toilet facilities, are to be obtained and paid for by the contractors performing the work described herein.
- B. Manufacturer Qualifications: Company specializing in the manufacture of flashing and sheet metal products for a minimum of 3 years.
- C. Applicator: Company well experienced in application of flashing and sheet metal products.
- D. All work shall be performed in strict accordance with applicable building codes and safety regulations.

1.6 DELIVERY, STORAGE AND HANDLING

- A. Store materials in weather protected environment, clear of ground and moisture, in accordance with manufacturer's instructions.

- B. Slope materials to provide positive drainage when stored outside.
- C. Store only acceptable project materials on-site as directed and approved by Owner/Owner's Representative.
- D. Deliver, handle, and store materials in accordance with manufacturer's instructions.
- E. Restrict storage to materials and related equipment.
- F. Keep all containers tightly closed when not in use.
- G. Remove empty containers, wrappings, and similar materials from building and grounds at end of each day's work.

1.7 WARRANTY

- A. Manufacturers: Submit manufacturer's standard material warranties.
- B. Applicator: Provide all labor and materials required to repair work that fails to perform for **five years** following the date of substantial completion.

PART 2 - PRODUCTS

2.1 MATERIALS

- A. Applications:
 - 1. Drip edge flashing
 - 2. Eave closure
 - 3. Roof edge flashing
 - 4. Chimney cricket flashing
 - 5. Valley flashing
 - 6. Parapet Cap Flashing
 - 7. Wall Flashing
 - 8. Cover Plates
 - 9. Continuous Cleats
 - 11. Plumbing stack flashing
 - 12. Sheet metal accessories
- B. Metal Type:
 - 1. Sheet Metal Flashing and Trim:
 - a. Aluminum: ASTM B 209 (ASTM B 209M), 3003 alloy, H14 temper; factory-applied paint finish.
 - b. Color: As selected by Owner.
 - 2. Sheet Lead: Minimum of 2-1/2 lb. per square foot.
 - 3. Sheet Metal: Stainless Steel ASTM 167, Type 316 with Mill Rolled No 2B.
- C. Metal thickness and size, unless otherwise shown on drawings, as follows:
 - 1. Drip Edge: (tile roof/fascia juncture)
 - a. Face Depth: 4"
 - 1) Aluminum: 0.040 in.
 - 2. Eave Closure:

- a. Manufacturer: East Coast Metals or approved equivalent
 - 1) Phone: 1-800-579-0944
 - 2) Website: www.eastcoast-metals.com
 - b. Face Depth: Match concrete tile
 - 1) Aluminum: 0.032 in.
 3. Roof Edge Flashing: (flat roof/tile roof juncture)
 - a. Face Depth: 5" minimum
 - 1) Aluminum: 0.040 in.
 4. Two Piece Counter Flashing:
 - a. Face Depth: 6"
 - 1) Aluminum: 0.040 in.
 5. Valley Flashing (closed valley):
 - a. Width: 16" min. (24" stretch-out) w/ a min. 2½" high diverter and a min. 1" edge return. Turn longitudinal edges of the 1" return in not less than 30 degrees and minimum ½" in height to prevent water overflowing.
 - b. Stainless Steel: Type 316.
 3. Chimney Cricket Flashing (behind each chimney):
 - a. Width: Sized to fit width of chimney
 - b. Vertical Flange: 5"
 - c. Base Flange: 6" w/ a min. 1" edge return. Turn longitudinal edges of the 1" return in not less than 30 degrees and minimum ½" in height to prevent water overflowing.
 - d. Aluminum: 0.040 in.
 6. Parapet Flashing and Cover Plates:
 - a. Aluminum: 0.040 in.
 7. Continuous Cleats:
 - a. Aluminum: One gauge heavier than the accessory metal.
 8. Wall Mounted Louvered Vents:
 - a. Size: Same as existing (Contractor shall field verify dimensions)
 - b. Aluminum: Minimum 0.040 in.
 9. Lead Skirted Plumbing Stacks:
 - a. Sheet Lead: Minimum 2.5 pounds per square foot thickness.
 10. Soakers/Skirts:
 - a. Sheet Lead: Minimum 2.5 pounds per square foot thickness.
- D. Fasteners:
1. Comply with SMACNA's "Architectural Sheet Metal Manual" and as follows:
 - a. Type: AISI 304 Series stainless steel.
 - b. At locations where fasteners are exposed, use screws with neoprene washers.
 - c. Polyfoam Products Inc. Polyset ONE Roof Tile Adhesive.
- E. Auxiliary Materials:
1. Solder compatible with metal.
 2. Bituminous isolation coating.
 3. Mastic and elastomeric sealants.
 4. Rosin-sized building paper slip-sheet.
 5. Asphaltic roofing cement.

2.2 FABRICATION

- A. Form sections true to shape, accurate in size, square, and free from distortion or defects.
- B. Fabricate continuous cleats of same material as sheet, interlocking with sheet.
- C. Form pieces in longest possible lengths.
- D. Hem exposed edges on underside $\frac{1}{2}$ "; miter and seam corners.
- E. Form material with flat lock seams, except where otherwise indicated on drawings. At moving joints, use sealed lapped, bayonet-type or interlocking hooked seams, except where otherwise indicated on drawings.
- F. Fabricate corners from one piece with minimum 18" long legs; seam for rigidity, seal with sealant.
- G. Fabricate vertical faces with bottom edge formed outward $\frac{1}{4}$ " and hemmed to form drip.
- H. Fabricate flashings to allow toe to extend 4" over roofing, except where otherwise indicated on drawings. Return and brake edges.

PART 3 - EXECUTION

3.1 INSTALLATION

- A. General:
 - 1. Secure flashings in place using concealed fasteners. Use exposed fasteners only where permitted.
 - 2. Apply plastic cement compound between metal flashings and felt flashings.
 - 3. Fit flashings tight in place. Make corners square, surfaces true and straight in plane and lines accurate to profiles.
 - 4. Seal metal joints watertight.
 - 5. Allow for expansion.
 - 6. Isolate dissimilar materials.
 - 7. Avoid direct contact with dissimilar metal, and with concrete or mortar.
 - 8. Before installing sheet metal, verify shapes and dimensions of surface to be covered.
- B. Except as detailed on drawings or specified otherwise, comply with details and recommendations of SMACNA's "Architectural Sheet Metal Manual."
- C. Install materials and systems in accordance with manufacturer's instructions and approved submittals. Install materials and systems in proper relation with adjacent construction and with uniform appearance. Coordinate with work of other sections.
- D. Dissimilar Materials: Coat with bituminous paint when in contact dissimilar materials e.g. concrete, mortar, pressure treated wood nailers, etc.
- E. Drip Edge Flashing (Tile Roof/Fascia Juncture):
 - 1. Form in 8 to 10 foot sections with provision for expansion at joints.

2. Joints: End lap 4" with a single lap. Apply a bead of sealant between lapping sections of metal at vertical face.
 3. Metal section securement:
 - a. Set flange of drip edge flashing in 1/8" bed of plastic roofing cement.
 - b. Nail flange as follows:
 - 1) Three inches on centers, staggered.
 - 2) Locate first row 1/2" - 3/4" from edge of flange.
 - c. Hook drip edge metal over continuous metal cleat.
 - 1) Joints in cleats are not to coincide with joints in drip edge flashing.
 - 2) Nail cleat at 6" on center near break of metal.
- F. Eave Closure:
1. Section Length: As provided by manufacturer.
 2. Joints: Butt
 3. Metal section securement:
 - a. Set flange on top of self-adhered membrane.
 - b. Nail flange as follows:
 - 1) Six inches on center.
 - 2) Install self-adhered underlayment over top of nailed flange.
- G. Parapet Flashing (Tile Roof/Flat Roof Juncture):
1. Form in 8 to 10 foot sections with provision for expansion at joints.
 2. Install with 3/4" opening between metal sections.
 3. Metal section securement:
 - a. Set flange of drip edge flashing in 1/8" bed of plastic roofing cement.
 - b. Nail flange as follows:
 - 1) Three inches on centers, staggered.
 - 2) Locate first row 1/2" - 3/4" from edge of flange.
 - c. Secure metal sections at each end under joint cover in the outside face with two nails through slotted holes.
 - d. Hook drip edge metal over continuous metal cleat.
 - 1) Joints in cleats are not to coincide with joints in drip edge flashing.
 - 2) Nail cleat at 6" on center near break of metal.
 4. Provide 6" wide cover plates at all joints.
 5. Set cover plates over 3/4" separation joints in metal sections in two beads of sealant (1" apart) approximately 1" in from the end of each metal section.
- H. Valley Flashing (closed valley):
1. Form in 8 to 10 foot sections.
 2. Install preformed closed valley metal on top of self-adhered underlayment membrane.
 3. Metal section securement:
 - a. Secure valley metal in place with metal strap clips fabricated from similar metal material.
 - b. Metal strap clips shall be 2" wide and spaced at 12" on center.
 - c. Hook 1" metal edge returns with metal strap clips fastened to roof deck with two (2) stainless steel roofing nails through metal strap. Do not flatten turn-up on flashing; do not nail through flashing.

- d. Joints: Overlap 6" minimum in direction of water flow. Blind nail each section of valley metal along its upper end. Apply 4 beads of sealant between overlapping sections of valley metal.
- I. Chimney Cricket Flashing (upslope of each chimney):
 1. Form in one piece with welded joints.
 2. Install preformed cricket metal on top of self-adhered underlayment membrane.
 3. Metal section securement:
 - a. Secure cricket metal in place with metal strap clips fabricated from similar metal material.
 - b. Joints: Overlapping metal shall be set in beads of sealant.
 - c. Vertical Flange:
 - 2) Nail top edge of vertical flange at 6" on center.
 - 3) Strip-in top of vertical flange with self-adhered membrane after nailing to wall.
 - d. Base Flange (with 1" return):
 - 3) Hook 1" metal edge returns with metal strap clips fastened to roof deck with two (2) stainless steel roofing nails through metal strap. Do not flatten turn-up on flashing; do not nail through flashing.
 - 4) Metal strap clips shall be 2" wide and spaced at 12" on center.
 - e. Base Flange (without 1" return) at Up Slope Side:
 - 5) Nail at top edge of base flange at 6" on center.
 - 6) Strip-in top of base flange with self-adhered membrane (peel-&-stick) after nailing to roof deck.
- J. Lead Skirted Plumbing Stacks:
 1. Make a watertight seal between the pipe and the self-adhered underpayment membrane (peel-&-stick).
 2. Apply lead skirted flashing over last field tile cut previously installed extending under the course of tile above the penetration. Ensure flashing is of sufficient width to redirect the water away from penetration.
 3. Crimp edges on three sides of lead skirt flashing at upside slope.
 4. Seal lead skirted flashing to tile as needed.
 5. Roll lead flashing into top of pipe approximately 1".
- K. Restore damaged components and finishes. Clean and protect work from damage.

END OF SECTION

SECTION 079200 - JOINT SEALANTS

PART 1 - GENERAL

1.1 RELATED DOCUMENTS

- A. Drawings and general provisions of the Contract, including General and Supplementary Conditions and Division 01 Specification Sections, apply to this Section.

1.2 SUMMARY

- A. Section Includes:
 - 1. Silicone joint sealants.
 - 2. Urethane joint sealants.

1.3 PREINSTALLATION MEETINGS

- A. Pre-installation Conference: Conduct conference at Spinnakers Reach I Condominiums, 700 Spinnakers Reach Drive, Ponte Vedra Beach, Florida 32082.

1.4 ACTION SUBMITTALS

- A. Product Data: For each joint-sealant product.
- B. Samples for Initial Selection: Manufacturer's color charts consisting of strips of cured sealants showing the full range of colors available for each product exposed to view.
- C. Samples for Verification: For each kind and color of joint sealant required, provide Samples with joint sealants in 1/2-inchwide joints formed between two 6-inchlong strips of material matching the appearance of exposed surfaces adjacent to joint sealants.
- D. Joint-Sealant Schedule: Include the following information:
 - 1. Joint-sealant application, joint location, and designation.
 - 2. Joint-sealant manufacturer and product name.
 - 3. Joint-sealant formulation.
 - 4. Joint-sealant color.

1.5 INFORMATIONAL SUBMITTALS

- A. Qualification Data: For qualified testing agency.
- B. Product Test Reports: For each kind of joint sealant, for tests performed by manufacturer and witnessed by a qualified testing agency.

- C. Pre-construction Laboratory Test Schedule: Include the following information for each joint sealant and substrate material to be tested:
 - 1. Joint-sealant location and designation.
 - 2. Manufacturer and product name.
 - 3. Type of substrate material.
 - 4. Proposed test.
 - 5. Number of samples required.
- D. Pre-construction Laboratory Test Reports: From sealant manufacturer, indicating the following:
 - 1. Materials forming joint substrates and joint-sealant backings have been tested for compatibility and adhesion with joint sealants.
 - 2. Interpretation of test results and written recommendations for primers and substrate preparation are needed for adhesion.
- E. Pre-construction Field-Adhesion-Test Reports: Indicate which sealants and joint preparation methods resulted in optimum adhesion to joint substrates based on testing specified in "Pre-construction Testing" Article.
- F. Field-Adhesion-Test Reports: For each sealant application tested.
- G. Sample Warranties: For special warranties.

1.6 QUALITY ASSURANCE

- A. Installer Qualifications: An authorized representative who is trained and approved by manufacturer.
- B. Product Testing: Test joint sealants using a qualified testing agency.
 - 1. Testing Agency Qualifications: Qualified according to ASTM C 1021 to conduct the testing indicated.
- C. Mockups: Install sealant in mockups of assemblies specified in other Sections that are indicated to receive joint sealants specified in this Section. Use materials and installation methods specified in this Section.

1.7 PRE-CONSTRUCTION TESTING

- A. Preconstruction Laboratory Testing: Submit to joint-sealant manufacturers, for testing indicated below, samples of materials that will contact or affect joint sealants.
 - 1. Adhesion Testing: Use ASTM C 794 to determine whether priming and other specific joint preparation techniques are required to obtain rapid, optimum adhesion of joint sealants to joint substrates.
 - 2. Compatibility Testing: Use ASTM C 1087 to determine sealant compatibility when in contact with glazing and gasket materials.
 - 3. Submit manufacturer's recommended number of pieces of each type of material, including joint substrates, joint-sealant backings, and miscellaneous materials.

4. Schedule sufficient time for testing and analyzing results to prevent delaying the Work.
 5. For materials failing tests, obtain joint-sealant manufacturer's written instructions for corrective measures, including use of specially formulated primers.
 6. Testing will not be required if joint-sealant manufacturers submit data that are based on previous testing, not older than 24 months, of sealant products for adhesion to, staining of, and compatibility with joint substrates and other materials matching those submitted.
- B. Pre-construction Field-Adhesion Testing: Before installing sealants, field test their adhesion to Project joint substrates as follows:
1. Locate test joints where indicated on Project or, if not indicated, as directed by Architect.
 2. Conduct field tests for each kind of sealant and joint substrate.
 3. Notify Architect seven days in advance of dates and times when test joints will be erected.
 4. Arrange for tests to take place with joint-sealant manufacturer's technical representative present.
 - a. Test Method: Test joint sealants according to Method A, Field-Applied Sealant Joint Hand Pull Tab, in Appendix X1.1 in ASTM C 1193 or Method A, Tail Procedure, in ASTM C 1521.
 - 1) For joints with dissimilar substrates, verify adhesion to each substrate separately; extend cut along one side, verifying adhesion to opposite side. Repeat procedure for opposite side.
 5. Report whether sealant failed to adhere to joint substrates or tore cohesively. Include data on pull distance used to test each kind of product and joint substrate. For sealants that fail adhesively, retest until satisfactory adhesion is obtained.
 6. Evaluation of Pre-construction Field-Adhesion-Test Results: Sealants not evidencing adhesive failure from testing, in absence of other indications of noncompliance with requirements, will be considered satisfactory. Do not use sealants that fail to adhere to joint substrates during testing.

1.8 FIELD CONDITIONS

- A. Do not proceed with installation of joint sealants under the following conditions:
1. When ambient and substrate temperature conditions are outside limits permitted by joint-sealant manufacturer or are below 40 deg F.
 2. When joint substrates are wet.
 3. Where joint widths are less than those allowed by joint-sealant manufacturer for applications indicated.
 4. Where contaminants capable of interfering with adhesion have not yet been removed from joint substrates.

1.9 WARRANTY

- A. Special Installer's Warranty: Installer agrees to repair or replace joint sealants that do not comply with performance and other requirements specified in this Section within specified warranty period.
 - 1. Warranty Period: **(5)** years from date of Substantial Completion.

- B. Special Manufacturer's Warranty: Manufacturer agrees to furnish joint sealants to repair or replace those joint sealants that do not comply with performance and other requirements specified in this Section within specified warranty period.
 - 1. Warranty Period: Number of years from date of Substantial Completion specified by the Manufacturer.

- C. Special warranties specified in this article exclude deterioration or failure of joint sealants from the following:
 - 1. Movement of the structure caused by stresses on the sealant exceeding sealant manufacturer's written specifications for sealant elongation and compression.
 - 2. Disintegration of joint substrates from causes exceeding design specifications.
 - 3. Mechanical damage caused by individuals, tools, or other outside agents.
 - 4. Changes in sealant appearance caused by accumulation of dirt or other atmospheric contaminants.

PART 2 - PRODUCTS

2.1 JOINT SEALANTS, GENERAL

- A. Compatibility: Provide joint sealants, backings, and other related materials that are compatible with one another and with joint substrates under conditions of service and application, as demonstrated by joint-sealant manufacturer, based on testing and field experience.

- B. Colors of Exposed Joint Sealants: As selected by the Engineer.

2.2 SILICONE JOINT SEALANTS

- A. Silicone, S, NS, 100/50, NT: Single-component, nonsag, plus 100 percent and minus 50 percent movement capability, nontraffic-use, neutral-curing silicone joint sealant; ASTM C 920, Type S, Grade NS, Class 100/50, Use NT.
 - 1. Manufacturers: Subject to compliance with requirements, provide products by the following:
 - a. Dow Corning.

2.3 URETHANE JOINT SEALANTS

- A. Urethane, S, NS, 100/50, T, NT: Single-component, nonsag, plus 100 percent and minus 50 percent movement capability, traffic- and nontraffic-use, urethane joint sealant; ASTM C 920, Type S, Grade NS, Class 100/50, Uses T and NT.
 - 1. Manufacturers: Subject to compliance with requirements, provide products by the following:
 - a. BASF Corporation-Construction Systems.

2.4 JOINT-SEALANT BACKING

- A. Sealant Backing Material, General: Non-staining; compatible with joint substrates, sealants, primers, and other joint fillers; and approved for applications indicated by sealant manufacturer based on field experience and laboratory testing.
 - 1. Manufacturers: Subject to compliance with requirements, provide products by the following:
 - a. Construction Foam Products; a division of Nomaco, Inc.
- B. Cylindrical Sealant Backings: ASTM C 1330, Type C (closed-cell material with a surface skin), and of size and density to control sealant depth and otherwise contribute to producing optimum sealant performance.
- C. Bond-Breaker Tape: Polyethylene tape or other plastic tape recommended by sealant manufacturer for preventing sealant from adhering to rigid, inflexible joint-filler materials or joint surfaces at back of joint. Provide self-adhesive tape where applicable.

2.5 MISCELLANEOUS MATERIALS

- A. Primer: Material recommended by joint-sealant manufacturer where required for adhesion of sealant to joint substrates indicated, as determined from preconstruction joint-sealant-substrate tests and field tests.
- B. Cleaners for Nonporous Surfaces: Chemical cleaners acceptable to manufacturers of sealants and sealant backing materials, free of oily residues or other substances capable of staining or harming joint substrates and adjacent nonporous surfaces in any way, and formulated to promote optimum adhesion of sealants to joint substrates.
- C. Masking Tape: Non-staining, nonabsorbent material compatible with joint sealants and surfaces adjacent to joints.

PART 3 - EXECUTION

3.1 EXAMINATION

- A. Examine joints indicated to receive joint sealants, with Installer present, for compliance with requirements for joint configuration, installation tolerances, and other conditions affecting performance of the Work.
- B. Proceed with installation only after unsatisfactory conditions have been corrected.

3.2 PREPARATION

- A. Surface Cleaning of Joints: Clean out joints immediately before installing joint sealants to comply with joint-sealant manufacturer's written instructions and the following requirements:
 - 1. Remove all foreign material from joint substrates that could interfere with adhesion of joint sealant, including dust, paints (except for permanent, protective coatings tested and approved for sealant adhesion and compatibility by sealant manufacturer), old joint sealants, oil, grease, waterproofing, water repellents, water, surface dirt, and frost.
 - 2. Clean porous joint substrate surfaces by brushing, grinding, mechanical abrading, or a combination of these methods to produce a clean, sound substrate capable of developing optimum bond with joint sealants. Remove loose particles remaining after cleaning operations above by vacuuming or blowing out joints with oil-free compressed air. Porous joint substrates include the following:
 - a. Concrete.
 - b. Masonry.
 - 3. Remove laitance and form-release agents from concrete.
 - 4. Clean nonporous joint substrate surfaces with chemical cleaners or other means that do not stain, harm substrates, or leave residues capable of interfering with adhesion of joint sealants. Nonporous joint substrates include the following:
 - a. Metal.
 - b. Glass.
 - c. Glazed surfaces of ceramic tile.
- B. Joint Priming: Prime joint substrates where recommended by joint-sealant manufacturer or as indicated by preconstruction joint-sealant-substrate tests or prior experience. Apply primer to comply with joint-sealant manufacturer's written instructions. Confine primers to areas of joint-sealant bond; do not allow spillage or migration onto adjoining surfaces.
- C. Masking Tape: Use masking tape where required to prevent contact of sealant or primer with adjoining surfaces that otherwise would be permanently stained or damaged by such contact or by cleaning methods required to remove sealant smears. Remove tape immediately after tooling without disturbing joint seal.

3.3 INSTALLATION OF JOINT SEALANTS

- A. General: Comply with joint-sealant manufacturer's written installation instructions for products and applications indicated, unless more stringent requirements apply.
- B. Sealant Installation Standard: Comply with recommendations in ASTM C 1193 for use of joint sealants as applicable to materials, applications, and conditions indicated.
- C. Install sealant backings of kind indicated to support sealants during application and at position required to produce cross-sectional shapes and depths of installed sealants relative to joint widths that allow optimum sealant movement capability.
 - 1. Do not leave gaps between ends of sealant backings.
 - 2. Do not stretch, twist, puncture, or tear sealant backings.
 - 3. Remove absorbent sealant backings that have become wet before sealant application, and replace them with dry materials.
- D. Install bond-breaker tape behind sealants where sealant backings are not used between sealants and backs of joints.
- E. Install sealants using proven techniques that comply with the following and at the same time backings are installed:
 - 1. Place sealants so they directly contact and fully wet joint substrates.
 - 2. Completely fill recesses in each joint configuration.
 - 3. Produce uniform, cross-sectional shapes and depths relative to joint widths that allow optimum sealant movement capability.
- F. Tooling of Non-sag Sealants: Immediately after sealant application and before skinning or curing begins, tool sealants according to requirements specified in subparagraphs below to form smooth, uniform beads of configuration indicated; to eliminate air pockets; and to ensure contact and adhesion of sealant with sides of joint.
 - 1. Remove excess sealant from surfaces adjacent to joints.
 - 2. Use tooling agents that are approved in writing by sealant manufacturer and that do not discolor sealants or adjacent surfaces.
 - 3. Provide concave joint profile per Figure 8A in ASTM C 1193 unless otherwise indicated.
 - a. Use masking tape to protect surfaces adjacent to recessed tooled joints.

3.4 FIELD QUALITY CONTROL

- A. Field-Adhesion Testing: Field test joint-sealant adhesion to joint substrates as follows:
 - 1. Extent of Testing: Test completed and cured sealant joints as follows:
 - a. Perform (2) tests for the first 1000 feet of joint length for each kind of sealant and joint substrate.
 - b. Perform one test for each 1000 feet of joint length thereafter or one test per each floor per elevation.
 - 2. Test Method: Test joint sealants according to Method A, Field-Applied Sealant Joint Hand Pull Tab, in Appendix X1 in ASTM C 1193 or Method A, Tail Procedure, in ASTM C 1521.

- a. For joints with dissimilar substrates, verify adhesion to each substrate separately; extend cut along one side, verifying adhesion to opposite side. Repeat procedure for opposite side.
 3. Inspect tested joints and report on the following:
 - a. Whether sealants filled joint cavities and are free of voids.
 - b. Whether sealant dimensions and configurations comply with specified requirements.
 - c. Whether sealants in joints connected to pulled-out portion failed to adhere to joint substrates or tore cohesively. Include data on pull distance used to test each kind of product and joint substrate. Compare these results to determine if adhesion complies with sealant manufacturer's field-adhesion hand-pull test criteria.
 4. Record test results in a field-adhesion-test log. Include dates when sealants were installed, names of persons who installed sealants, test dates, test locations, whether joints were primed, adhesion results and percent elongations, sealant material, sealant configuration, and sealant dimensions.
 5. Repair sealants pulled from test area by applying new sealants following same procedures used originally to seal joints. Ensure that original sealant surfaces are clean and that new sealant contacts original sealant.
- B. Evaluation of Field-Adhesion-Test Results: Sealants not evidencing adhesive failure from testing or noncompliance with other indicated requirements will be considered satisfactory. Remove sealants that fail to adhere to joint substrates during testing or to comply with other requirements. Retest failed applications until test results prove sealants comply with indicated requirements.

3.5 CLEANING

- A. Clean off excess sealant or sealant smears adjacent to joints as the Work progresses by methods and with cleaning materials approved in writing by manufacturers of joint sealants and of products in which joints occur.

3.6 PROTECTION

- A. Protect joint sealants during and after curing period from contact with contaminating substances and from damage resulting from construction operations or other causes so sealants are without deterioration or damage at time of Substantial Completion. If, despite such protection, damage or deterioration occurs, cut out, remove, and repair damaged or deteriorated joint sealants immediately so installations with repaired areas are indistinguishable from original work.

3.7 JOINT-SEALANT SCHEDULE

- A. Joint-Sealant Application: Exterior joints vertical surfaces and horizontal non-traffic surfaces.
 1. Joint Locations:
 - a. Joints in any change in plane.

- b. Joints in any dissimilar materials.
 - c. Perimeter joints between materials listed above and frames of doors, windows and louvers.
 - d. Other joints as indicated on Drawings.
 2. Joint Sealant: BASF Masterseal NP 150
 3. Joint-Sealant Color: As selected by Architect from manufacturer's full range of colors
TBD.
- B. Joint-Sealant Application: Exterior joints in vertical surfaces and horizontal non-traffic surfaces.
 1. Joint Locations:
 - a. Construction joints in cast-in-place concrete.
 - b. Control and expansion joints.
 - c. Other joints as indicated on Drawings.
 2. Joint Sealant: Dow Corning 790.
 3. Joint-Sealant Color: As selected by Architect from manufacturer's full range of colors
TBD.

END OF SECTION 079200

Section 092400 - Portland Cement Plastering (Stucco)

PART 1 – GENERAL

1.10 SUMMARY

A. Specification provides requirements for the applications of a Stucco System, including general information, pertaining to the design, materials and application of Stucco.

B. Related Sections: Other specification sections which relate directly to the work of this section include the following:

- Section 033000 – Concrete
- Section 042200 – Concrete Unit Masonry
- Section 054100 – Structural Metal Stud Framing
- Section 061100 – Wood Framing
- Section 061600 - Sheathing
- Section 072400 – Exterior Insulation and Finish Systems
- Section 072500 – Weather barriers
- Section 076000 – Flashing and Sheet Metal
- Section 079200 – Joint Sealants
- Section 099000 – Painting and Coating

1.20 SUBMITTALS

A. The following is a list of documents that is required to be provided for review prior to commencement of scope within this section.

1. Product literature.
2. Samples and/or mock-ups of system.
3. Certification of compliance of materials and/or product literature.
4. Product literature for all additives and proprietary components.
5. Finish sample for texture and color for engineer/owner approval.

1.30 REFERENCES

- A Building Codes – International, NFRA, California, Uniform
- B. American Concrete Institute
- C. Federal Specifications:

FS UU-B-790a: Building Papers
FS FF-N-105B: Nails, Wire Staples for Applications of Gypsum Board
FS QQ-W-461H: Wire, Steel and Carbon (round, bare & coated)

D. Portland Cement Plaster (Stucco) Manual by PCA

E. Stucco Resource Guide (NWCB)

F. National Building Code – Canada

G. ASTM Standards:

ASTM A526: Steel Sheet, Hot-Dip Galvanized, Commercial Quality
ASTM C91: Masonry Cement
ASTM C109: Compressive Strength of Hydraulic Cement Mortars
ASTM C144: Aggregate
ASTM C150: Portland Cement
ASTM C207: Hydrated Lime for Masonry Purposes
ASTM C260: Air-Entraining Admixtures
ASTM C348: Flexural Strength of Hydraulic Cement Mortar
ASTM C494: Chemical Admixtures for Concrete
ASTM C834: Standard Specification for Latex Sealants
ASTM C841: Installation of Interior Lathing and Furring
ASTM C847: Metal Lath
ASTM C897: Aggregate for Job-Mixed Portland Cement Plaster
ASTM C926: Application of Portland Cement-Based Plaster
ASTM C932: Surface-Applied Bonding Agents for Exterior Plastering
ASTM C979: Pigments for Integrally Colored Concrete
ASTM C1032: Woven Wire Plaster Base
ASTM C1063: Installation of Lathing and Furring for Portland Cement Plaster
ASTM D1784: Rigid Poly (Vinyl Chloride) PVC Compounds
ASTM E72: Strength Tests of Panels for Building Construction
ASTM E119: Methods for Fire Tests of Building Construction and Materials
ASTM E514: Method for Water Penetration and Leakage Through Masonry

1.40 **QUALITY ASSURANCE**

A. Pre-installation meeting.

B. Wall assembly fire-resistance rating:

-) Construction documents shall indicate the type of fire and/or sound assembly ratings required for project.
-) Construction documents to indicate fire-resistance assembly test required.

C. Applicator qualifications. The plastering company shall meet the following requirements:

1. Specialize in this scope of work.
2. Have qualified and properly trained people to perform work.
3. Be licensed, bonded and insured.
4. Be in good financial standing and capable of meeting the financial obligations associated with the stucco scope of work on the project.
5. Have documented experience in quality work of comparable scope.

1.50 DELIVERY, STORAGE AND HANDLING

- A. Deliver products in original packaging, labeled with product identification, manufacturer, batch number, and shelf life.
- B. All trim accessories and lath and/or other specified products to be shipped to job site in original containers. Any damaged or bent materials shall be replaced.
- C. Handle products in accordance with manufacturer's printed recommendations.

1.60 ENVIRONMENTAL CONDITIONS

A. Cold Weather Conditions:

1. Do not apply cement plaster when ambient temperature is less than 35°F (2°C).
2. Do not apply cement plaster to any frozen surfaces or surfaces containing frost. Protect plaster coats against freezing for a period of 24 hours after application.
3. Do not use frozen materials.
4. Tenting, heat and ventilation must be provided if cement plastering is done in a temperature below 35°F (2°C).

B. Warm Weather Conditions:

1. Protect the basecoats and finish coat of cement plaster from uneven and excessive evaporation in warm, windy weather. (Refer to section on curing in PART III)
2. Moist curing of cement based plaster is required.

PART 2 – PRODUCTS

2.10 MOISTURE BARRIER

A. Water-resistant paper – Federal Specification UU-B-790a, grade D/30-minute or 60-minute.

2.15 WINDOW HEAD, DOOR, LOUVER AND/OR OTHER PENETRATION-PLUS WALL OPENING PAN-TYPE FLASHING – 26-GAUGE GALVANIZED SHEET METAL, OR PVC PLASTIC

2.20 RUNNER- AND CROSS-FURRING CHANNELS

Cold-rolled galvanized steel channels, 1 1/2 inch (38 mm) and 3/4 inch (19 mm), a minimum of 33,000 psi yield strength and a minimum of 0.0538-inch bare steel thickness, ASTM A526.

) Suspended soffits/ceilings – 1 1/2-inch (38 mm) main runner, 3/4-inch (19 mm) cross furring.

2.25 FURRING “HAT” CHANNELS

Furring channel, galvanized 7/8-inch (22 mm), 20-gauge.

2.30 MECHANICAL FASTENERS

A. Non-corroding fasteners, depending on the type framing or substrate:

1. Wood Framing – minimum 11 gauge, 7/16 inch (11 mm) diameter head galvanized roofing nails with minimum 3/4 inch (19 mm) penetration into studs or minimum #8 Type S wafer head fully threaded corrosion resistant screws with minimum 3/4 inch (19 mm) penetration into studs. (Nails: FS FF-N-105; Screws: ASTM C646)
2. Steel Framing – minimum #8 Type S or S-12 wafer head fully threaded corrosion resistant screws with minimum 3/8 inch (10 mm) penetration into studs. (Screws: ASTM C646)
3. Concrete or Masonry – minimum #8 wafer head fully threaded corrosion resistant screws for masonry with minimum 1 inch (25 mm) penetration into substrate. (Screws: ASTM C646)
4. Wood framing with EPS board over OSB board or plywood sheathing- Wire lath shall be fastened with corrosion resistant nails or 1” wide crown staples which penetrate at least 1” into the studs.

- B. Tie Wire – 18 gauge galvanized and annealed low-carbon steel in compliance with ASTM A641 with Class I coating. (FS QQ-W-461g. AS)

2.40 **LATH**

- A. Self-furring 1 inch (25 mm) woven wire lath minimum No. 20 gauge, galvanized. Shall comply with ASTM 1032.
- B. Self-furring diamond-mesh metal lath galvanized, 2.5 or 3.5 lb per sq. yd. Shall comply with ASTM 847.
- C. 3/8-inch (10 mm) rib lath, galvanized. ASTM 847.

2.50 **TRIM ACCESSORIES**

-) Trim Accessories shall be fabricated from galvanized steel, zinc (alloy), PVC or anodized aluminum.
-) Depth (the grounds) of accessories depends on the required thickness of cement plaster basecoat, without the finish coat.
-) Accessories of PVC plastic or zinc (alloy) are recommended if corrosion is a concern because of environmental conditions.

- A. Steel accessories per ASTM C 841
- B. PVC plastic accessories per ASTM D1784 & C1063
- C. Aluminum accessories from extruded alloy 6063 T5
- D. General types of accessories:

1. Foundation weep screed: _____

2. Casing bead type no. 66 (JMOLD): _____

3. Corner reinforcement (corner bead): _____

E. Soffit vents _____

F. Drip screeds _____

G. Trim accessory joints (control joints), expansion joints, or reveals _____

-) Construction documents shall reference type, style and manufacturers of accessories.

2.60 **BONDING AGENTS**

- A. Type II Ethylene Polyvinyl Acetate Co–Polymer Bonding Agent for Portland Cement Repair Mortars. Comply with the following:
1. Manufacturer: Concrete Bonding Adhesive (No. 9902) as manufactured by the QUIKRETE® Companies, One Securities Centre, 3490 Piedmont Road, NE, Suite 1300, Atlanta, GA 30305; telephone (404) 634-9100.
 2. Performance and Physical Properties at 73°F (23°C) and 50% relative humidity.
 - a. Application: Spray, brush or roller application or applied as a blended Portland Cement/Bonding Adhesive slurry coat.
 - b. Bond Strength, ASTM C1059: > 1250 psi (8.6 MPa) @ 20 days.
 - c. Combustibility: Non-combustible, both before and after use.

2.70 **BASE COAT STUCCO MATERIALS**

- A. Factory proportioned, alkali resistant, fiberglass reinforced, Portland cement based stucco designed for one-coat basecoat application. Comply with the following:
1. Manufacturer: One Coat Fiberglass Reinforced Stucco – Sanded (No. 1200), One Coat Fiberglass Reinforced Stucco – Concentrated (No. 1216) as manufactured by the QUIKRETE® Companies, One Securities Centre, 3490 Piedmont Road, NE, Suite 1300, Atlanta, GA 30305; telephone (404) 634-9100.
 2. Performance and Physical Properties at 73 degrees F (23 degrees C) and 50 percent relative humidity.
 - a. One Coat Fiberglass Reinforced Stucco – Sanded (No. 1200)
 1. Compressive strength at 28 days, ASTM C109: 2020 psi (13.9 MPa)
 2. Flexural strength at 28 days, ASTM C348: 570 psi (3.9 MPa)
 3. Tensile strength at 28 days, ASTM C109: 180 psi (1.2 MPa)
 4. Wind driven rain, average flow, 24 hours ASTM E514: 0.002 lb (0.9 g) per hours
 5. Freeze/thaw resistance, ICBO Acceptance Criteria 9/30/85 : No visible cracking, checking or delamination after 10 F/T cycles of 75° to -20°F (24° to -29°C)

6. Water vapor permeability, ASTM E514: 7.2 perm (415 ng/(Pa x s x m²)) @ 14 days

7. Transverse load strength, ASTM E72

Wood studs, average load to failure: 96 psf (469 kg/m²)

Metal studs, average load to failure: 138 psf (674 kg/m²)

8. Fire rating: One hour fire rating applied over:

OSB Sheathing

Plywood Sheathing

OSB and EPS Foam

Plywood and EPS Foam

b. One Coat Fiberglass Reinforced Stucco – Concentrated (No. 1216)

1. Compressive strength at 28 days, ASTM C109: 2020 psi (13.9 MPa)

2. Flexural strength at 28 days, ASTM C348: 570 psi (3.9 MPa)

3. Tensile strength at 28 days, ASTM C109: 180 psi (1.2 MPa)

4. Wind driven rain, average flow, 24 hours ASTM E514: 0.002 lb (0.9 g) per hours

5. Freeze/thaw resistance, ICBO Acceptance Criteria 9/30/85 : No visible cracking, checking or delamination after 10 F/T cycles of 75° to -25°F (24° to -29°C)

6. Water vapor permeability, ASTM E514: 7.2 perm (415 ng/(Pa x s x m²)) @ 14 days

7. Transverse load strength, ASTM E72

Wood studs, average load to failure: 96 psf (469 kg/m²)

Metal studs, average load to failure: 138 psf (674 kg/m²)

8. Fire rating: One hour fire rating applied over:

OSB Sheathing

Plywood Sheathing

OSB and EPS Foam

Plywood and EPS Foam

B. Factory proportioned, Portland cement based exterior stucco for use in scratch and brown coat stucco applications. Comply with the following:

1. Manufacturer: Base Coat – Scratch and Brown Coat Stucco (No. 1139.80), Base Coat Stucco with Water-Stop (No. 1139-86) as manufactured by the QUIKRETE® Companies, One Securities Centre, 3490 Piedmont Road, NE,

2. Performance and Physical Properties at 73 degrees F (23 degrees C) and 50 percent relative humidity.

a. Base Coat Stucco Scratch and Brown Coat (No. 1139.80)

1. Compressive Strength, ASTM C109:

900 psi (6.2 MPa) @ 7 days

1200 psi (8.3 MPa) @ 28 days

2. Compliance, ASTM C 926

b. Base Coat Stucco with Water-Stop (No. 1139-80)

1. Compressive Strength, ASTM C109:

900 psi (6.2 MPa) @ 7 days

1,200 psi (8.3 MPa) @ 28 days

2. Wind Driven Rain, ASTM E514: 0.002 lb (0.9 g) per hours

3. Compliance, ASTM C926

2.80 **FINISH COAT MATERIALS**

A. Factory proportioned stucco finish color and texture coat. Comply with the following:

1. Manufacturer: Finish Coat Stucco (White – No. 1201; Gray – No.1202) as manufactured by the QUIKRETE® Companies, One Securities Centre, 3490 Piedmont Road, NE, Suite 1300, Atlanta, GA 30305; telephone (404) 634-9100.

2. Performance and Physical Properties at 73 degrees F (23 degrees C) and 50 percent relative humidity.

a. Compressive Strength, ASTM C109:

900 psi (6.2 MPa) @ 7 days

1200 psi (8.3 MPa) @ 28 days

b. Compliance, ASTM C926 (Type F Plaster)

2.90 **ACRYLIC FINISH COAT MATERIALS**

A. Factory proportioned, pre-mixed 100%, acrylic, co-polymer finish color and texture coat.

Comply with the following:

1. Manufacturer: Liquid Stucco Acrylic Finish Coat (Swirl No. 132000, Fine No.132200, Coarse No. 132100) as manufactured by the QUIKRETE® Companies, One Securities Centre, 3490 Piedmont Road, NE, Suite 1300, Atlanta, GA 30305; telephone (404) 634-9100.
2. Performance and Physical Properties at 73 degrees F (23 degrees C) and 50 percent relative humidity.
 - a. Water Vapor and Permanence, ASTM E96: 212 perm (121.688 ng/(Pa x s x m²))
 - b. Accelerated Weathering, ASTM G 26 & G 23: No blistering, cracking or shipping after 1000 hours minimum
 - c. Salt Spray Resistance, ASTM B117: No deleterious effects after 1000 hours minimum
 - d. Wind Driven Rain, Federal Specification TT-C-555B: No effect, passes test
 - e. Chemical Resistance, ASTM D1308 (Method A): No deleterious effects

-) 20% NaOH
-) Clorox™
-) 2 Fuel Oil
-) Mineral Spirits
-) Vinegar
-) Gasoline
-) Ethyl Alcohol
-) 29% NH₄OH

PART 3 EXECUTION

3.10 EXAMINATION

- A. Prior to starting lathing or plastering work, carefully inspect installed work of other trades to verify that work is complete to the point where work of this section may properly commence.
- B. Notify the engineer or proper authorities in writing of conditions detrimental to the proper and timely completion of the lathing and/or plastering work.
- C. Do not begin installation until all unsatisfactory conditions are resolved.
- D. A pre-construction meeting is recommended with the engineer and/or owner, primary contractor and representatives responsible for the windows, framing, flashing, roofing, sealants, stucco and any other building components interfacing with the stucco.

3.20 **PERFORMANCE**

- A. The work shall be performed by a skilled and trained work crew.
- B. Install specified products and/or systems in accordance with reference standards, manufacturer's recommendations, unless indicated otherwise in project documents.
- C. Flashing shall be installed prior to start of lathing or may be required to be integrated at the time of lathing.

3.30 **INSTALLATION OF STUCCO TRIM ACCESSORIES**

- A. Verify that substrate and work by other trades are complete to the point at which installation of trim accessories may properly commence.
- B. Attachments shall be firm enough to hold trim accessories in place without misalignment during plastering.
 -) Flanges or attachment points of trim accessories shall be secured to substrate in accordance with requirements of manufacturers of approved fasteners. Space per manufacturer's directions.
- C. PVC is recommended if trim accessories are exposed to a high-salt environment.
- D. Install individual trim-accessory sections to each other at end joints for accurate alignment.
- E. Install trim accessories in a manner that ensures a true, level and plumb stucco surface, and moisture resistant.
- F. Install the trim accessories in accordance with the required thickness of stucco basecoat and finish coat requirements.
- G. Install the longest possible lengths of trim accessories. A minimum continuous section (length) of 7 ft (2 m) is recommended.

3.35 **TRIM ACCESSORY JOINTS**

- A. The water-resistant barrier must continue to be unbroken behind trim accessory joints in vertical or horizontal direction.
- B. Locate trim accessory joints strategically at points where building movement is anticipated.
 - 1. Wall penetrations
 - 2. Structural plate lines
 - 3. Junctures of dissimilar substrates
 - 4. Existing construction joints in structure
 - 5. Columns

6. Cantilevered areas

- C. Joints are recommended in stucco assemblies with lath reinforcement but have limited use in direct-applied stucco over concrete or concrete masonry surface.
- D. It is recommended that trim accessory joints be weather-sealed by embedment in caulking at intersections when placed end-to-end and at the terminations.
- E. It is recommended to install vertical joints continuously and abut them to horizontal joints (be sure that water-resistant barrier runs continuously behind joints).
- F. Install longest possible lengths. No termination of a section within 24 inches (600 mm) of an intersection, with the exception of pre-manufactured trim accessory joint intersections.
- G. Trim accessory joints shall be installed on framed, sheathed construction so as to create stucco panel of 150 to 180 sq. ft. (14 m² to 17 m²) in as square a configuration as possible.
- H. Trim accessory joints shall be installed with concrete or concrete masonry construction so as to create a stucco assembly (with lath reinforcement) of 200 to 250 sq. ft. (18 m² to 23 m²).
- I. Installing control joints over continuous lath is an approved method.
- J. Sheathed framed construction with vertical trim accessory joints that require the lath to be terminated (cut) and installed on top of the flanges shall be placed at framing member locations. Lath shall be attached with appropriate fasteners through the trim accessory flange, sheathing and into the framing member.

3.40

3.50 **SURFACE PREPARATION**

- A. Surfaces must be clean dry and free of dust, dirt, oil and other foreign matter.

3.60 **MIXING**

Comply with manufacturer's printed instructions and the following:

A. Base Coats

- 1. One Coat Fiberglass Reinforced Stucco – Sanded. Comply with manufacturer's printed instructions and the following:
 - a. Fiberglass Reinforced Stucco shall be mechanically mixed in a paddle-type mortar mixer for 3-5 min.
 - b. Add approximately 1.75 gallons (6.6 L) of clean mixing water into the mixing container for

each 80 lb (36.3 kg) bag. Add the powder to the mixing water and mix until a firm, workable consistency is achieved. Avoid over mixing as this may affect the integrity of the AR glass fibers. If more water is needed, add small amounts at a time and continue to mix until desired consistency is achieved. Prepare only enough mix as can be applied in one hour.

c. To improve Fiberglass Reinforced Stucco's water resistance, impact resistance, strength and durability 1/2 gallon (1.9 L) of QUIKRETE® Acrylic Fortifier can be used as a replacement for 0.5 gallon (1.9 L) of mixing water per bag.

d. Do not exceed a total volume of 2 gallons (7.6 L) of water for each 80 lb (36.3 kg) bag.

2. One Coat Fiberglass Reinforced Stucco – Concentrated. Comply with manufacturer's printed instructions and the following:

a. Fiberglass Reinforced Stucco – Concentrated should be mechanically mixed in a paddle-type mortar mixer for 2-3 min.

b. Add approximately 6 gallons (23 L) of clean mixing water into the mixer for each 90 lb (40.8 kg) bag.

c. Add approximately 240 lb (109 kg) of clean dry plaster sand (ASTM C897). Pour the powder into the mixer and mix until a firm, workable consistency is achieved. Avoid over mixing as this may affect the integrity of the AR glass fibers. Mixing water will vary with sand loading and moisture content. If more water is needed, add small amounts at a time and continue to mix until desired consistency is achieved. Prepare only enough mix as can be applied in one hour.

d. To improve Fiberglass Reinforced Stucco's water resistance, impact resistance, strength and durability 1/2 gallon (1.9 L) of QUIKRETE® Acrylic Fortifier can be used as a replacement for 0.5 gallon (1.9 L) of mixing water per bag.

e. Do not exceed a total volume of 7 gallons (26.6 L) of water for each 90 lb (40.8 kg) bag.

3. Base Coat Stucco. Comply with manufacturer's printed instructions and the following:

a. Base Coat Stucco should be mixed mechanically in a paddle-type mortar mixer.

b. Add approximately 1.5 gallons (5.7 L) of clean mixing water into the mixing container for each 80 lb (36.3 kg) bag. Add the powder into the mixing water and mix until a firm, workable consistency is achieved. If more water is needed, add small amounts at a time and continue to mix until desired consistency is achieved. Prepare only enough mix as can be applied in one hour.

c. To improve Fiberglass Reinforced Stucco's water resistance, impact resistance, strength and durability 1/2 gallon (1.9 L) of QUIKRETE® Acrylic Fortifier can be used as a replacement for 0.5 gallon (1.9 L) of mixing water per bag.

d. Do not exceed a total volume of 14 pints (6.6 L) of water for each 80 lb (36.3 kg) bag.

4. Base Coat Stucco with Water-Stop. Comply with manufacturer's printed instructions and the following:

- a. Base Coat Stucco with Water-Stop should be mechanically mixed in a paddle-type mortar mixer.
- b. Add approximately 1.5 gallons (5.7 L) of clean mixing water into the mixing container for each 80 lb (36.3 kg) bag. Add the powder into the mixing water and mix until a firm, workable consistency is achieved. If more water is needed, add small amounts at a time and continue to mix until desired consistency is achieved. Prepare only enough mix as can be applied in one hour.
- c. To improve Fiberglass Reinforced Stucco's water resistance, impact resistance, strength and durability 1/2 gallon (1.9 L) of QUIKRETE® Acrylic Fortifier can be used as a replacement for 0.5 gallon (1.9 L) of mixing water per bag.
- d. Do not exceed a total volume of 14 pints (6.6 L) of water for each 80 lb (36.3 kg) bag.

B. Finish Coat

1. Finish Coat Stucco. Comply with manufacturer's printed instructions and the following:

- a. Finish Coat Stucco should be mechanically mixed in a paddle type mortar mixer for 2-3 min.
- b. Add approximately 2 gallons (7.6 L) of clean mixing water into the mixing container for each 80 lb (36.3 kg) bag. Add the powder into the mixing water and mix until a firm, workable consistency is achieved. If more water is needed, add small amounts at a time and continue to mix until desired consistency is achieved. Prepare only enough mix as can be applied in one hour.
- c. To improve Fiberglass Reinforced Stucco's water resistance, impact resistance, strength and durability 1/2 gallon (1.9 L) of QUIKRETE® Acrylic Fortifier can be used as a replacement for 0.5 gallon (1.9 L) of mixing water per bag.
- d. If a colored decorative finish is desired, QUIKRETE® Stucco and Mortar Color (#1319) can be added directly to the mixing water.
- e. Do not exceed a total volume of 2 1/4 gallons (8.6 L) of water for each 80 lb (36.3 kg) bag.

2. Liquid Stucco Acrylic Finish Coat. Comply with manufacturer's printed instructions and the following:

- a. Liquid Stucco should be mechanically mixed in the bucket with a 1/2-inch (12.7-mm) drill and paddle until a firm consistency is achieved.
- b. Up to 12 fl oz (350 ml) of liquid pigment and water may be added per 60 lb (27 kg) pail.

3.70 APPLICATIONS OF STUCCO BASECOAT FOR SOFFITS

- A. Indicate factory proportioned QUIKRETE® Base Coat Mix to be used.
- B. Apply stucco first (“scratch”) coat in a nominal thickness of 3/8 inch (10 mm). First coat should completely embed the lath. First coat should be thick enough to allow for scoring of cement plaster surface. Scratch horizontal grooves 1/8 inches (3 mm) deep across the surface of the basecoat mortar.
 -) QUIKRETE® One Coat Fiberglass Reinforced Stucco required only one 3/8 inch (10 mm) coat eliminating the need for a second 3/8 inch (10 mm) coat.
- C. Moist cure the first (“scratch”) coat for a minimum of 48 hours before application of the second (“brown”) coat.
- D. Apply stucco second (“brown”) coat in a nominal thickness of 3/8 inch (10 mm) over stucco first coat. Second coat thickness to bring the combined basecoats (first and second) thickness to a nominal thickness of 3/4 inch (19 mm).
- E. Apply the second coat with sufficient material and pressure to ensure a tight uniform bond to the first coat.
- F. Screed the second coat to a true, even plane, filling surface defects with cement plaster.
- G. Trowel-float the second coat surface uniformly.

3.71 CURING OF SOFFIT BASECOAT – Refer to section 3.93

3.72 STUCCO FINISH COAT – Refer to section 3.94

3.73 ACRYLIC FINISH COAT – Refer to section 3.95

3.74 TWO COAT STUCCO DIRECT TO CONCRETE

- A. Apply QUIKRETE® Concrete Bonding Adhesive directly to concrete surface only in accordance with the recommendation of manufacturer of the material.
- B. Install trim accessories – termination trim accessory, corner reinforcements (corner beads), trim accessory joints (control joints) and other specified accessories in accordance with sections 3.30 and 3.35.
- C. Indicate type of stucco termination trim accessory (casing bead):

Indicate name of manufacturer (optional):

D. Attach termination trim accessory to concrete surface with hardened concrete stub nails; low-velocity, power-actuated pins or drill-and-drive fasteners. Fastener heads minimum of 3/8-inch (10-mm) diameter, length of fasteners 3/4 inch (19 mm); spacing of fasteners 8 to 12 inches (200 to 300 mm) o.c.

E. Indicate the type of corner reinforcement (corner bead):

Indicate name of manufacturer (optional):

F. Attach corner reinforcement to concrete surface with hardened concrete stub nails; low-velocity, power-actuated pins or drill-and-drive fasteners. Fastener heads minimum of 3/8-inch (10-mm) diameter, length of fasteners 3/4 inch (19 mm); spacing of fasteners 12 inches (300 mm) o.c. staggered.

G. Indicate the type of trim accessory joint (control joint, expansion joint, reveal or other style):

Indicate name of manufacturer (optional):

-) The use of trim accessory joints (control joints) is limited on a stucco system direct to concrete masonry, and they are not required as frequently as for framed construction.
-) Control or expansion joints are recommended at locations of concrete expansion joints (construction joints).
-) Control joints are recommended if the area exceeds 250 sq. ft. (23 m²). Panel should be in as square configuration as possible.

I. Attach trim accessory joints to concrete surface with hardened concrete stub nails; low-velocity, power-actuated pins or drill-and-drive fasteners. Fastener heads minimum of 3/8-inch (10-mm) diameter, length of fasteners 3/4 inch (19 mm); spacing of fasteners 12 inches (300 mm) o.c. staggered.

J. Application of stucco basecoat.

K. Indicate the factory proportioned QUIKRETE® BaseCoat Mix to be used:

Refer to section 2.70

L. Apply basecoat (brown coat) in a normal thickness of 3/8 inch (10 mm).

M. Apply basecoat with sufficient material and pressure to ensure tight contact with concrete surface and uniform thickness.

N. Screed the basecoat to a true and even plane, filling basecoat surface defects with cement plaster.

O. Trowel-float the basecoat surface uniformly.

3.75 **CURING OF BASECOAT** – Refer to section 3.94

3.76 **STUCCO FINISH COAT** – Refer to section 3.95

3.77 **ACRYLIC FINISH COAT** – Refer to section 3.97

3.78 **TWO-COAT STUCCO DIRECT TO CONCRETE MASONRY “CMU”**

-) Reinforcement lath is omitted in this system. Do not tool the mortar joints of the concrete masonry assembly. It is recommended to have mortar joints struck flush with the surface.
-) Coated (painted) concrete masonry surfaces require self-furring lath attached in accordance with standards or the removal of the coating.

A. Install trim accessories – termination trim accessories (casing beads), corner reinforcement (corner beads); trim accessory joints (control joints) and other specified accessories to sections 3.30 and 3.35 to concrete masonry substrate.

B. Trim Accessory Attachment

-) For substrates of concrete masonry units, brick or tile, it is recommended that the fasteners be placed in the mortar joints. This will minimize damage to the individual units.

C. Indicate types of termination trim accessories (casing beads):

D. Attach termination trim accessory to concrete masonry surface with hardened concrete stub nails; low-velocity, power-actuated pins or drill-and-drive fasteners. Fastener heads minimum of 3/8-inch (10-mm) diameter; length of fasteners 3/4 inch (19 mm); spacing of fasteners 8 to 12 inches (200 to 300 mm) o.c.

E. Indicate the type of corner reinforcement (corner bead):

F. Attach corner reinforcement to concrete masonry surface with hardened concrete stub nails; low-velocity, power-actuated pins or drill-and-drive fasteners. Fastener heads minimum of 3/8-inch (10-mm) diameter, length of fasteners 3/4 inch (19 mm); spacing of fasteners 12 inches (300 mm) o.c. staggered.

G. Indicate the type of trim accessory joint (control joint, expansion joint, reveal or other style):

-
-) Control joints are recommended if the area exceeds 250 sq. ft. (23 m²). Panel should be in as square a configuration as possible.
 -) Control or expansion joints are recommended at locations of concrete masonry expansion joints.

H. Attach trim accessory joint to concrete masonry surface with hardened concrete stub nails; low-velocity, power-actuated pins or drill-and-drive fasteners. Fastener heads minimum of 3/8-inch (10-mm) diameter; length of fasteners 3/4 inch (19 mm); spacing of fasteners 12 inches (300 mm) o.c. staggered.

J. Indicate factory proportioned QUIKRETE® BaseCoat Mix to be used for the basecoat:

Refer to section 2.70

-) Delete basecoat mixes not applicable to this project.

K. Apply basecoat (brown coat) in a nominal thickness of 1/2 inch (13 mm).

-) Basecoat direct to concrete masonry surface 3/8 inch (10 mm) to 5/8 inch (13 mm) thick, not greater than 5/8 inch (13 mm).

L. Apply basecoat with sufficient material and pressure to ensure tight contact with concrete masonry surface and uniform thickness.

-) Dampen the substrate by spraying with clean water prior to plastering.
-) It is advisable first to apply a dash bond coat or liquid bonder to the concrete masonry surface in order to uniform the suction and help prevent the telegraphing of the mortar joints. Dash coat does not replace one of the specified number of coats.

M. Screed the basecoat to a true, even plane, filling basecoat surface defects with cement plaster.

N. Trowel-float the basecoat surface uniformly.

3.79 **CURING OF BASECOAT** – Refer to section 3.94

3.80 **STUCCO FINISH COAT** – Refer to section 3.95

3.81 **ACRYLIC FINISH COAT** – Refer to section 3.97

3.82 **STUCCO ASSEMBLY ATTACHED TO CONCRETE**

-) Concrete surface to be in good condition, no large voids, no spalling and no delamination. Concrete to be true and straight.
-) Concrete to be cured a minimum of 30 days before start of any stucco work.

-) A water-resistant barrier is not required for this stucco assembly. A combination self-furring lath and water-resistant barrier (paperback lath) is recommended if the project documents specify a water-resistant barrier.
- A. Install trim accessories – termination trim accessories (casing beads), corner reinforcement (corner beads), trim accessory joints (control joints) and other specified accessories in accordance with sections 3.30 and 3.35.
- B. Indicate type of stucco termination trim accessory (casing bead): _____
- C. Attach termination trim accessory to concrete surface with low-velocity, power-actuated pins or drill-and-drive fasteners. Fastener heads minimum of 3/8-inch (10-mm) diameter, length of fasteners 3/4 inch (19mm); spacing of fasteners 8 to 12 inches (200 to 300 mm) o.c.
- D. Indicate the type of corner reinforcement (corner bead): _____
- E. Attach corner reinforcement to concrete surface with low-velocity, power-actuated pins or drill-and-drive fasteners. Fastener heads minimum of 3/8-inch (10-mm) diameter, length of fasteners 3/4 inch (19 mm); spacing of fasteners 12 inches (300 mm) o.c. staggered, or attach to lath with 18-gauge tie wire, spaced 12 inches (300 mm) o.c. staggered.
- F. Indicate the type of trim accessory joint (control joint, expansion joint, reveal or other style):

-) Control joints are recommended for areas greater than 200 sq. ft. (18 m²). Maximum recommended length of a panel is 20 ft (6 m). Panel size should not exceed a 3-to-1 ratio.
- G. Attach trim accessory joints to concrete surface with low-velocity, power-actuated pins or drill-and-drive fasteners. Fastener heads minimum of 3/8-inch (10-mm) diameter, length of fasteners 3/4 inch (19 mm); spacing of fasteners 12 inches (300 mm) o.c.
- H. Installation of expansion joints requires lath to be cut and attached to both sides of the expansion joint flange staggered 12 inches (300 mm) o.c., attach with wire ties or appropriate fasteners into concrete surface. (Control joints installed on top of lath.)
- I. Install galvanized self-furring diamond-mesh metal lath, 2.5 or 3.4 pounds per sq. yd. (1.4 kg/m² or 1.8 kg/m²) to vertical concrete surface (walls). For horizontal concrete surfaces (ceilings), use 3.4-pound-per-square-yard (1.8 kg/m²) self-furring lath.
-) Lath shall be applied with the long dimension of sheets horizontal.

- J. Attach lath to concrete surface with hardened concrete stub nails; low-velocity, power-actuated pins or drill-and-drive fasteners. Fastener heads minimum of 3/8-inch (10-mm) diameter, length of fasteners 3/4 inch (19 mm).
- K. Spacing of fasteners for 2.5-pound-per-square-yard lath to walls shall be 16 inches (400 mm) o.c. horizontally and 7 inches (180 mm) o.c. vertically. Spacing of fasteners for 3.4-pound-square-inch lath to walls shall be 24 inches (600 mm) o.c. horizontally and 6 inches (180 mm) vertically. Spacing of fasteners for lath to ceilings shall be 16 inches (400 mm) and 7 inches (180 mm) o.c.

3.83 **STUCCO ASSEMBLY ATTACHED TO CONCRETE/APPLICATION OF STUCCO BASECOAT –**
Refer to section 3.93

3.84 **CURING OF BASECOAT –** Refer to section 3.94

3.85 **STUCCO FINISH COAT –** Refer to section 3.95

3.86 **ACRYLIC FINISH COAT –** Refer to section 3.97

3.87 **STUCCO ASSEMBLY ATTACHED TO CONCRETE MASONRY**

- J A concrete masonry wall must have been cured in accordance with industry standards (a minimum of 30 days) before application of stucco assembly.
- J Do not tool the mortar joints of the concrete masonry assembly. It is recommended to have mortar joints struck flush with the surface.
- A. Install trim accessories – termination trim accessories (casing beads), corner reinforcements (corner beads); trim accessory joints (control joints) and other specified accessories in accordance with sections 3.30 and 3.35.
- B. Trim accessory and lath attachment
 - J For substrates of concrete masonry units, brick or tile, it is recommended that the fasteners be placed in the mortar joints. (This will minimize damage to the individual units.)
- C. Indicate type of termination trim accessory (casing bead/foundation weep screed):

–
- D. Attach termination trim accessory to concrete masonry surface with hardened concrete stub nails; low-velocity, power-actuated pins and drill-and-drive fasteners. Fastener heads minimum 3/8 inch (10-mm) diameter, length of fasteners 3/4 inch (19 mm); spacing of fasteners 12 inches (300 mm) o.c.

- E. Indicate the type of corner reinforcement (corner bead): _____
- F. Attach corner reinforcement to concrete masonry surface with hardened concrete stub nails; low-velocity, power-actuated pins or drill-and-drive fasteners. Fastener heads minimum of 3/8-inch (10-mm) diameter, length of fasteners 3/4 inch (19 mm); spacing of fasteners 12 inches (300 mm) o.c. staggered.
- G. Indicate type of trim accessory joint (control joint, expansion joint, reveal or other style) :
- _____
-) Control or expansion joints are recommended at locations of concrete masonry expansion joints (construction joints).
 -) Trim accessory joints (control joints) are recommended, by not as frequently as for framed construction.
 -) Control joints are recommended for areas greater than 200 sq. ft. Maximum recommended length of a panel is 20 ft (6 m). Panel size should not exceed a 3-to-1 ratio.
- H. Attach trim accessory joints to concrete masonry surface with hardened concrete stub nails; low-velocity, power-actuated pins or drill-and-drive fasteners. Fastener heads minimum of 3/8-inch (10-mm) diameter, length of fasteners 3/4 inch (19 mm); spacing of fasteners 12 inches (300 mm) o.c. staggered,
- I. Installation of expansion joints requires lath to be cut and attached to both sides of the expansion joint 12 inches (300 mm) o.c. staggered, with appropriate fasteners, into concrete masonry joints.
- J. Installation of lath reinforcement to concrete masonry
-) A water-resistant barrier is not normally required or recommended for this stucco assembly. A combination self-furring lath and water-resistant barrier (paper-backed lath) is the style of lath recommended if the project documents specify a water-resistant barrier over the concrete masonry substrate.
- K. Indicate type of self-furring lath:
- _____
- Refer to section 2.40 for lath selection.
- L. Attach lath to concrete masonry surface with hardened concrete stub nails; low-velocity, power-actuated pins or drill-and-drive fasteners. Fastener heads minimum of 3/8-inch (10-mm) diameter, length of fasteners 3/4 inch (19 mm).
- M. Spacing of fasteners for attachment of woven wire lath, welded wire lath and 2.5-pound-per-square-yard diamond-mesh lath: 16 inches (400 mm) o.c. horizontally. For attachment of 3.4-pound-per-square-yard diamond-mesh lath: 24 inches (600 mm) o.c. horizontally. Vertical attachment of lath shall be 7 inches (180 mm).

3.88 **STUCCO ASSEMBLY ATTACHED TO CONCRETE MASONRY / APPLICATIONS OF STUCCO BASECOAT** – Refer to section 3.93

3.89 **CURING OF BASECOAT** – Refer to section 3.94

3.90 **STUCCO FINISH COAT** – Refer to section 3.95

3.91 **ACRYLIC FINISH COAT** – Refer to section 3.97

3.92 **STUCCO ASSEMBLY TO SHEATHED CONSTRUCTION**

-) It is recommended that the minimum size of wood framing member the stucco system is going to be over 2x4 standard or better grade.
 -) It is recommended that the minimum size of steel framing members be 3 1/2 inches (88 mm) and a minimum of 20-gauge (0.0329).
 -) Open-frame construction is an approved framing method for attachment of stucco assembly, but not recommended for best performance.
 -) Exterior sheathing board to have firm contact with framing members (no gaps).
 -) Framing assembly (substrate) to be true, straight and level. Align in accordance with its application standards.
 -) It is recommended that the wood framing and wood sheathing board have a moisture content of less than 19% before starting the scope of the stucco work.
 -) The substrate to which the stucco systems is attached must be rigid and a minimum design deflection of L/360.
 -) Appropriate exterior sheathing boards over which to install the stucco assembly:
 1. Exterior gypsum sheathing
 2. Glass-mat gypsum sheathing
 3. Cementitious backer board (may require paperback lath)
 4. Exterior-grade plywood
 5. Oriented strand board
 -) Exterior-grade plywood and oriented strand boards shall be installed with a minimum of 1/8 inch (3 mm) gap along all panel edges and ends.
 -) Exterior sheathing board, once installed, requires protection from climatic conditions, until the installation of the stucco system.
 -) Sections of flashing or trim accessories that butt each other (at corners or another condition) need to be lapped, caulked, or have a strip of self-adhering membrane over the joints to prevent moisture intrusion into the building structure.
- A. Install a water-resistant barrier “WRB” as part of the stucco assembly. Water-resistant barrier, per F.S. UU-B-790A grade D 60-minute; spun-bounded olefin housewrap for a stucco system, or an approved weather-resistant barrier designed for a stucco system.

-) It is required to use water-resistant barriers with all wood or steel framed structures.

-) Two layers of Grade D 60-minute building paper are required over the wood sheathing.
 -) It is recommended that two layers of water-resistant barrier be installed over all types of sheathing boards.
 -) All flashing and water-resistant barrier to be installed in such a manner so as to prevent moisture from entering at all edges (tops and sides).
 -) The water-resistant barrier is to be installed “shingle-fashion” so that natural direction of water flow would be over and onto the next sheet.
 -) Install long dimension horizontal to framing.
 -) Water-resistant barrier shall have horizontal laps of 2 inches (50 mm) minimum. Vertical laps shall be 6 inches (150 mm) minimum.
- B. Attach water-resistant barrier to sheathing with small staples so as it is taut and flat. Refer to details in the “Window Flashing Applications” section.
- C. Install stucco system trim accessories – foundation weep screed, casing beads, corner reinforcements (corner beads), trim accessory joints (control joints, expansion joints, reveals) and other specified accessories in accordance with sections 3.30 and 3.35.
- D. Trim accessory and lath attachment
-) Lath shall be applied with long dimension of the sheets or rolls horizontal (perpendicular) to framing members. Apply lath taut.
 -) Bend lath and continue around corners to next framing member and/or corner reinforcement
 -) Attachment of lath should be at furring points.
 -) Fasteners to penetrate a minimum of 3/4 inch (19 mm) into wood framing members.
 -) Fasteners to be centered on flange (ends) or framing member. A minimum of 3/8 inch (10 mm) from edge. Both legs of staple to penetrate framing member.
 -) Fasteners to penetrate a minimum of 2 full threads past the steel framing member flange.
- E. Indicate type of termination-at-foundation trim accessory (foundation weep screed, as required by Building Code): _____
- F. Fasteners for attachment of trim accessories, foundation trim and lath
-) Wood-sheathed framing:
 1. Roofing nails: 11-gauge · 7/16-diameter head · 1 1/2 inches long (i.e., 1/2 inch wood sheathing)
 2. Staples: 16-gauge · 3/4-inch crown · 1 3/8 long (i.e., 1/2 inch wood sheathing)
 3. Type W screws: wafer head · 1 1/2 inches long (i.e., 1/2 inch wood sheathing)
 -) Sheathed steel framing:
 1. Type S screws: wafer head · self-drilling · 1 inch (25 mm) long (i.e., 1/2 inch sheathing)

- G. Indicate type of foundation trim accessory (foundation weep screed or casing bead):

- H. Attach foundation trim accessory to building structure, with appropriate fastener selected from list in section 3.92-G. Spacing of fasteners 12 inches (300 mm) o.c.

- I. Indicate type of termination trim accessory (casing bead):

- J. Attach termination trim accessory to building structure, with appropriate fastener selected from list in section 3.92-G. Spacing of fasteners 12 inches (300 mm) o.c.

- K. Indicate type of corner reinforcement (corner bead):

- L. Attach corner reinforcement to building structure, with appropriate fastener selected from list in section 3.92-G, or attach to lath with 18-gauge tie wire. Spacing of fasteners 12 inches (300 mm) o.c. staggered.

- M. Indicate the type of trim accessory joint (control joint, expansion joint, reveal or other style):

- N. Attach trim accessory joints to building structure, with appropriate fastener selected from list in the section 3.92-G. Spacing of fasteners 12 inches (300 mm) o.c. staggered.

-) Joints are recommended if the area is 150 to 180 sq. ft (14 to 17 m²). Maximum recommended length of a panel is 18 ft. (6 m). Panel size should not exceed a 3-to-1 ratio.
-) The application of sealants is recommended in conjunction with the installation of trim accessory joints. Refer to section 3.35 and details in the "Trim Accessory Joints" section.
-) A continuous (unbroken) water-resistant barrier is required behind all trim accessory joints.
-) Control joints are the type of trim accessory joints recommended for installation over continuous (unbroken) lath. Expansion joints and reveals are types of trim accessory joints which require the lath to be broken behind the joint.
-) If attachment of control joints is to lath or other trim accessories, use 18-gauge wire tie 12 inches (300 mm) o.c. to each flange, staggered.
-) Aluminum and/or PVC reveals require that when the lath is installed over the flange, it totally covers it. The welded wire and woven wire lath shall be installed so as the crotch of the lath is over the flange.

- O. Installation of expansion joints and reveals requires lath to be cut and attached to both sides of the joint flange.

- P. Indicate type of self-furring lath:

(Refer to section 2.40 for lath selection)

- Q. Attach lath to building structure, with appropriate fastener selected from list in section 3.92-G.
-) Install lath with long dimension of sheets/rolls horizontal, perpendicular to framing members.
 -) Bend lath and continue around corners to next framing member or install corner beads.
- R. For attachment of 2.5-pound-per-square-yard diamond-mesh lath, the spacing of framing “studs” shall be 16 inches (400 mm) o.c. For attachment of woven wire lath, welded wire lath and 3.4-pound-per-square-yard diamond-mesh lath, the spacing of framing “studs” shall be 24 inches (600 mm) o.c. Vertical fasteners for attachment of all lath to studs shall be 6 inches (150 mm) o.c. (fasteners to penetrate into framing supports studs).
-) Refer to section 3.36 on trim accessory and lath attachment.
 -) All spacing is maximum.

APPLICATION OF STUCCO BASECOAT

- A. Indicate the factory proportioned QUIKRETE® Basecoat to be used:

Refer to section 2.70

- B. 1. Apply One Coat Fiberglass Reinforced Stucco onto the lath working from bottom to top at a minimum thickness of 3/8 inches (10 mm). Force the fiberglass reinforced stucco through the mesh so that it fits the gap between the mesh and wall completely. Screed the stucco surface flat and float, smooth the surface once the stucco has lost its sheen.
-) One Coat Fiberglass Reinforced Stucco may be spray or trowel applied.
2. Apply Basecoat Stucco first (“scratch”) coat in a nominal thickness of 3/8 inch (10 mm). First coat to completely embed the lath. First coat to be thick enough to go beyond lath so as to allow for scoring of cement plaster surface. Scratch horizontal grooves 1/8 inch (3 mm) deep across the surface of the basecoat mortar.
-) Basecoat Stucco maybe spray or trowel applied.
 -) Allow first coat to cure 48 hours before applying second (brown) coat.
 -) Dampen the surface of the first (scratch) coat with a fine spray of water.
- C. Apply stucco second (“brown”) coat in a nominal thickness of 3/8 inch (10 mm) over stucco first coat. Second coat thickness to bring the combined basecoats (first and second) thickness to a nominal

thickness of 3/4 inch (19 mm). Complete the entire wall section in one work session to minimize color differences.

- D. Apply the second coat with sufficient material and pressure to ensure a tight uniform bond to the first coat.
- E. The “double-back” method of applying successive coats is recommended. This procedure has little or no delay between applying the second coat over the first cot.
- F. Screed the second coat to a true, even plane, filling surface defects with cement plaster.
- G. Trowel-float the second coat surface uniformly.
 -) The floating process densifies the basecoat and provides a proper surface for the finish coat application.
 -) Float the basecoat after it has set and when moisture is still present in it. (The float should not adhere to the surface that is to be worked).
 -) Floating the basecoat that is to receive an acrylic finish coat is critical because of the thickness of this finish.

3.94 **CURING OF BASECOAT**

- A. 1. One Coat Fiberglass Reinforced Stucco must be water cured with a fine mist once it has achieved final set. Spray the wall periodically for 48 hours. During hot and dry conditions, additional precautions may be necessary, including more frequent spraying, or the erection of barriers to deflect sunlight and wind.

2. Basecoat Stucco must be water cured with a fine mist once it has achieved final set. Spray the wall periodically for 48 hours. During hot and dry conditions, additional precautions may be necessary, including more frequent spraying, or the erection of barriers to deflect sunlight and wind.
- B. The stucco basecoat should be protected from freezing for a period of 24 hours after application.
 -) Do not moist-cure if basecoat is subject to freezing.
 -) Do not use frozen materials in mix.
 -) Do not apply cement plaster to a surface that is frozen or contains frost.

3.95 **STUCCO FINISH COAT**

- A. Stucco basecoat (or concrete surface) is required to be in a proper condition before application of stucco finish coat or acrylic finish coat
- B. Dampen stucco basecoat evenly with a fine water spray. Do not soak surface.
- C. Trowel or spray apply Finish Coat Stucco at a minimum 1/8 inches (3.2 mm) thickness starting at the bottom and working to the top of the wall.

- D. Smooth Finish Coat Stucco with a darby and allow application to take an initial set prior to beginning texturing operations. Avoid overlapping previously dried areas.
- E. Apply desired surface texture with a brush or trowel. Complete texture application while the mix is till workable.
- F. Indicate the type of stucco finish coat:

Manufactured stucco finish: QUIKRETE® Finish Coat Stucco

- G. Indicate the style of stucco finish:

Refer to section 3.92 G-1

- 1. Styles of stucco finish:

- a. Sand Float Finish (fine, medium or course)
- b. Machine Dash Finish (light/medium/heavy)
- c. Knockdown Dash Finish
- d. Lace Finish
- e. Light Comb Finish
- f. English Finish
- g. Spanish Finish

- I. Indicate the color of stucco finish:

3.96 CURING FINISH COAT STUCCO

- A. Finish Coat Stucco must be water cured with a fine mist once it has achieved final set. Care must be exercised to avoid erosion damage to the finish surface. Uneven curing may result in color variations. Spray the wall periodically for several days. During hot and dry conditions, additional precautions may be necessary, including more frequent spraying or the erection of barriers to deflect sunlight and wind.

Precautions: Temperature, wind velocity, direct sunlight or shading, as well as the dampness or dryness of the surface receiving the material, all have an effect on the finished depth of color. Do not apply when weather is forecast to be above 100 F° (4 C°) within 24 hours without adopting the required hot and cold weather precautions.

3.97 ACRYLIC FINISH COAT

- A. Indicate style of acrylic finish:

Indicate color of acrylic finish:

Manufacturer's approved acrylic finish: QUIKRETE® Liquid Stucco Acrylic Finish Coat

) Refer to manufacturer for different styles and color selection.

- B. Apply acrylic finish over stucco basecoat (brown coat) or concrete surface minimum of 1/16 inch (2 mm) dry thickness.
- C. Apply acrylic finish coat with sufficient material to uniformly and completely cover the basecoat.

3.98 **ADDITIONAL TYPES OF FINISHES**

- A. Factory-mixed 100% acrylic-based elastomeric finish
- B. High-quality exterior acrylic paint
 -) Applied per manufacturer's recommendations over a stucco finish or acrylic finish.
- C. High-quality exterior elastomeric paint
 -) Applied over a stucco finish coat or acrylic finish coat.

END OF SECTION

SECTION 099113 - EXTERIOR PAINTING

PART 1 - GENERAL

1.1 RELATED DOCUMENTS

- A. Drawings and general provisions of the Contract, including General and Supplementary Conditions and Division 01 Specification Sections, apply to this Section.

1.2 SUMMARY

- A. Section includes surface preparation and the application of paint systems on the following exterior substrates:
 - 1. Concrete.
 - 2. Concrete masonry units (CMUs).
 - 3. Steel and iron.
 - 4. Galvanized metal.
 - 5. Aluminum.
 - 6. Copper.
 - 7. Stainless steel.
 - 8. Wood.
 - 9. Fiberglass.
 - 10. Plastic.
 - 11. Portland cement plaster (stucco).
 - 12. Exterior Insulation Finishing System (EIFS).
 - 13. Concrete roof tiles.

1.3 DEFINITIONS

- A. MPI Gloss Level 1: Not more than five units at 60 degrees and 10 units at 85 degrees, according to ASTM D 523.
- B. MPI Gloss Level 3: 10 to 25 units at 60 degrees and 10 to 35 units at 85 degrees, according to ASTM D 523.
- C. MPI Gloss Level 4: 20 to 35 units at 60 degrees and not less than 35 units at 85 degrees, according to ASTM D 523.
- D. MPI Gloss Level 5: 35 to 70 units at 60 degrees, according to ASTM D 523.
- E. MPI Gloss Level 6: 70 to 85 units at 60 degrees, according to ASTM D 523.
- F. MPI Gloss Level 7: More than 85 units at 60 degrees, according to ASTM D 523.

1.4 ACTION SUBMITTALS

- A. Product Data: For each type of product. Include preparation requirements and application instructions.
 - 1. Include printout of current "MPI Approved Products List" for each product category specified, with the proposed product highlighted.
 - 2. Indicate VOC content.
- B. Samples for Initial Selection: For each type of topcoat product.
- C. Samples for Verification: For each type of paint system and each color and gloss of topcoat.
 - 1. Submit Samples on rigid backing, 8 inches square.
 - 2. Apply coats on Samples in steps to show each coat required for system.
 - 3. Label each coat of each Sample.
 - 4. Label each Sample for location and application area.
- D. Product List: Cross-reference to paint system and locations of application areas. Use same designations indicated on Drawings and in schedules. Include color designations.

1.5 MAINTENANCE MATERIAL SUBMITTALS

- A. Furnish extra materials from the same product run that match products installed and that are packaged with protective covering for storage and identified with labels describing contents.
 - 1. Paint: (5) percent, but not less than, 2 gal. of each material and color applied.

1.6 QUALITY ASSURANCE

- A. Mockups: Apply mockups of each paint system indicated and each color and finish selected to verify preliminary selections made under Sample submittals and to demonstrate aesthetic effects and set quality standards for materials and execution.
 - 1. Architect will select one surface to represent surfaces and conditions for application of each paint system.
 - a. Vertical and Horizontal Surfaces: Provide samples of at least 100 sq. ft..
 - b. Other Items: Architect will designate items or areas required.
 - 2. Final approval of color selections will be based on mockups.
 - a. If preliminary color selections are not approved, apply additional mockups of additional colors selected by Engineer at no added cost to Owner.

3. Approval of mockups does not constitute approval of deviations from the Contract Documents contained in mockups unless Engineer specifically approves such deviations in writing.
4. Subject to compliance with requirements, approved mockups may become part of the completed Work if undisturbed at time of Substantial Completion.

1.7 DELIVERY, STORAGE, AND HANDLING

- A. Store materials not in use in tightly covered containers in well-ventilated areas with ambient temperatures continuously maintained at not less than 45 deg F.
 1. Maintain containers in clean condition, free of foreign materials and residue.
 2. Remove rags and waste from storage areas daily.

1.8 FIELD CONDITIONS

- A. Apply paints only when temperature of surfaces to be painted and ambient air temperatures are between 40 and 95 deg F
- B. Do not apply paints in snow, rain, fog, or mist; when relative humidity exceeds 85 percent; at temperatures less than 5 deg F above the dew point; or to damp or wet surfaces.

PART 2 - PRODUCTS

2.1 MANUFACTURERS

- A. Manufacturers: Subject to compliance with requirements, provide products by one of the following:
 1. Benjamin Moore & Co or approved equal.
 2. Coronado Paint; Benjamin Moore Company or approved equal.
- B. Products: Subject to compliance with requirements, provide product or equivalent listed in the Exterior Painting Schedule for the paint category indicated.

2.2 PAINT, GENERAL

- A. MPI Standards: Products shall comply with MPI standards indicated and shall be listed in its "MPI Approved Products Lists."
- B. Material Compatibility:
 1. Materials for use within each paint system shall be compatible with one another and substrates indicated, under conditions of service and application as demonstrated by manufacturer, based on testing and field experience.

2. For each coat in a paint system, products shall be recommended in writing by topcoat manufacturers for use in paint system and on substrate indicated.
- C. VOC Content: Products shall comply with VOC limits of authorities having jurisdiction.
- D. Colors: As selected by Owner.

2.3 SOURCE QUALITY CONTROL

- A. Testing of Paint Materials: Owner reserves the right to invoke the following procedure:
 1. Owner will engage the services of a qualified testing agency to sample paint materials. Contractor will be notified in advance and may be present when samples are taken. If paint materials have already been delivered to Project site, samples may be taken at Project site. Samples will be identified, sealed, and certified by testing agency.
 2. Testing agency will perform tests for compliance with product requirements.
 3. Owner may direct Contractor to stop applying paints if test results show materials being used do not comply with product requirements. Contractor shall remove noncomplying paint materials from Project site, pay for testing, and repaint surfaces painted with rejected materials. Contractor will be required to remove rejected materials from previously painted surfaces if, on repainting with complying materials, the two paints are incompatible.

PART 3 - EXECUTION

3.1 EXAMINATION

- A. Examine substrates and conditions, with Applicator present, for compliance with requirements for maximum moisture content and other conditions affecting performance of the Work.
- B. Maximum Moisture Content of Substrates: When measured with an electronic moisture meter as follows:
 1. Concrete: 12 percent.
 2. Masonry: 12 percent.
- C. Portland Cement Plaster Substrates: Verify that plaster is fully cured.
- D. Verify suitability of substrates, including surface conditions and compatibility, with existing finishes and primers.
- E. Proceed with coating application only after unsatisfactory conditions have been corrected.
 1. Application of coating indicates acceptance of surfaces and conditions.

3.2 PREPARATION

- A. Comply with manufacturer's written instructions and recommendations in "MPI Architectural Painting Specification Manual" applicable to substrates and paint systems indicated.
- B. Remove hardware, covers, plates, and similar items already in place that are removable and are not to be painted. If removal is impractical or impossible because of size or weight of item, provide surface-applied protection before surface preparation and painting.
 - 1. After completing painting operations, use workers skilled in the trades involved to reinstall items that were removed. Remove surface-applied protection.
- C. Clean substrates of substances that could impair bond of paints, including dust, dirt, oil, grease, and incompatible paints and encapsulates.
 - 1. Remove incompatible primers and re-prime substrate with compatible primers or apply tie coat as required to produce paint systems indicated.
- D. Concrete Substrates: Remove release agents, curing compounds, efflorescence, and chalk. Do not paint surfaces if moisture content or alkalinity of surfaces to be painted exceeds that permitted in manufacturer's written instructions.
- E. Masonry Substrates: Remove efflorescence and chalk. Do not paint surfaces if moisture content or alkalinity of surfaces or mortar joints exceeds that permitted in manufacturer's written instructions.
- F. Apply paints according to manufacturer's written instructions and recommendations in "MPI Architectural Painting Specification Manual."
 - 1. Use applicators and techniques suited for paint and substrate indicated.
 - 2. Paint surfaces behind movable items same as similar exposed surfaces. Before final installation, paint surfaces behind permanently fixed items with prime coat only.
 - 3. Paint both sides and edges of exterior doors and entire exposed surface of exterior door frames.
 - 4. Do not paint over labels of independent testing agencies or equipment name, identification, performance rating, or nomenclature plates.
 - 5. Primers specified in painting schedules may be omitted on items that are factory primed or factory finished if acceptable to topcoat manufacturers.
- G. Tint undercoats same color as topcoat, but tint each undercoat a lighter shade to facilitate identification of each coat if multiple coats of same material are to be applied. Provide sufficient difference in shade of undercoats to distinguish each separate coat.
- H. If undercoats or other conditions show through topcoat, apply additional coats until cured film has a uniform paint finish, color, and appearance.
- I. Apply paints to produce surface films without cloudiness, spotting, holidays, laps, brush marks, roller tracking, runs, sags, or other surface imperfections. Cut in sharp lines and color breaks.

J. Painting Fire Suppression, Plumbing, HVAC, Electrical, Communication, and Electronic Safety and Security Work:

1. Paint the following work where exposed to view:
 - a. Uninsulated metal piping.
 - b. Uninsulated plastic piping.
 - c. Pipe hangers and supports.
 - d. Metal conduit.
 - e. Plastic conduit.

3.3 FIELD QUALITY CONTROL

A. Dry Film Thickness Testing: Owner may engage the services of a qualified testing and inspecting agency to inspect and test paint for dry film thickness.

1. Contractor shall touch up and restore painted surfaces damaged by testing.
2. If test results show that dry film thickness of applied paint does not comply with paint manufacturer's written recommendations, Contractor shall pay for testing and apply additional coats as needed to provide dry film thickness that complies with paint manufacturer's written recommendations.

3.4 CLEANING AND PROTECTION

- A. At end of each workday, remove rubbish, empty cans, rags, and other discarded materials from Project site.
- B. After completing paint application, clean spattered surfaces. Remove spattered paints by washing, scraping, or other methods. Do not scratch or damage adjacent finished surfaces.
- C. Protect work of other trades against damage from paint application. Correct damage to work of other trades by cleaning, repairing, replacing, and refinishing, as approved by Architect, and leave in an undamaged condition.
- D. At completion of construction activities of other trades, touch up and restore damaged or defaced painted surfaces.

3.5 EXTERIOR PAINTING SCHEDULE

Note: Application of paint/coating and film thickness requirements to be in accordance with manufacturers recommendations according technical data sheets. Field verify project conditions with manufacturer's recommendations.

- A. EIFS Substrates – new or existing:
 1. Primer/Sealer – One coat Benjamin Moore's Elastomeric Waterproofer (055) or approved equal.

2. Finish – Two coats Benjamin Moore’s Aura Exterior Acrylic Low Luster (634) or approved equal.
- B. Stucco Substrates – existing:
 1. Finish - Two coats Benjamin Moore’s Aura Exterior Acrylic Low Luster (634) or approved equal.
- C. Concrete Substrates, Non -Traffic Surfaces:

Previously Painted Areas:

 1. Primer/Sealer – One coat Benjamin Moore’s Latex Masonry Conditioner (066) or approved equal.
 2. Finish – One coat Benjamin Moore’s Aura Exterior Acrylic Low Luster (634) or approved equal.
- D. CMU Substrates:
 1. Primer/Sealer – One coat Benjamin Moore’s Latex Masonry Conditioner (066) or approved equal.
 2. Finish – One coat Benjamin Moore’s Aura Exterior Acrylic Low Luster (634) or approved equal.
- E. Steel and Iron Substrates:
 1. Primer – One coat Benjamin Moore’s Corotech Universal Alkyd Metal Primer (V132) or approved equal.
 2. Finish – Two coats Benjamin Moore’s Corotech DTM Acrylic SG (V341) or approved equal.
- F. Galvanized-Metal Substrates:
 1. Primer – One coat Benjamin Moore’s Corotech Waterborne Bonding Primer (V175) or approved equal.
 2. Finish – Two coats Benjamin Moore’s Corotech DTM Acrylic SG (V331) or approved equal.
- G. Aluminum Substrates: Garage Doors
 1. Primer – Benjamin Moore’s Corotech Waterborne Bonding Primer (V175) or approved equal.
 2. Finish – Two coats Benjamin Moore’s Corotech DTM Acrylic SG (V331) or approved equal.
- H. Wood:
 1. Finish – Two coats Benjamin Moore Aura Acrylic Low Luster (641) or approved equal.
- I. Concrete Roof Tiles:
 1. Finish – Two coats Benjamin Moore Ultra Spec EXT Acrylic (N448) or approved equal.

END OF SECTION 099113

THIS DRAWING IS THE PROPERTY OF CONSTRUCTION SOLUTIONS, INC. ANY USE OR REPRODUCTION WITHOUT THE EXPRESSED WRITTEN CONSENT OF CONSTRUCTION SOLUTIONS, INC. IS PROHIBITED. ALL RIGHTS OF DESIGN AND INVENTION ARE EXPRESSLY RESERVED.

GENERAL

1. THE STRUCTURAL DRAWINGS SHALL GOVERN THE WORK FOR ALL STRUCTURAL FEATURES, UNLESS NOTED OTHERWISE.
2. THE METHOD AND FREQUENCY OF ATTACHING MECHANICAL EQUIPMENT UNITS ETC. TO THE STRUCTURAL ELEMENTS SHALL BE SUBJECT TO THE ENGINEER'S REVIEW AND APPROVAL.
3. CONTRACTOR SHALL VISIT THE SITE TO OBSERVE CONDITIONS PRIOR TO BEGINNING CONSTRUCTION.
4. THE CONTRACTOR SHALL VERIFY ALL EXISTING CONDITIONS, DIMENSIONS, ETC. AND SHALL NOTIFY THE ENGINEER OF ANY AND ALL DISCREPANCIES, ADDITIONAL INFORMATION, ETC. BEFORE BEGINNING THE WORK.
5. THE CONTRACTOR SHALL USE EXTREME CAUTION IN THE DEMOLITION OF EXISTING STRUCTURES. SUCH, DEMOLITION SHALL BE PERFORMED IN SUCH A MANNER AS TO MAINTAIN THE STRUCTURAL INTEGRITY OF ALL EXISTING STRUCTURES TO REMAIN. PROVIDE SHORING AS REQUIRED.
6. THE CONTRACTOR SHALL PREPARE A WRITTEN DEMOLITION PLAN TO BE SUBMITTED TO THE ENGINEER. THIS PLAN IS TO INDICATE, AS A MINIMUM, SEQUENCE OF DEMOLITION OPERATION, LOCATION OF PROPOSED TEMPORARY SHORING, SCAFFOLDING, BRACING, ETC. AND PROPOSED METHOD OF DEMOLITION.
7. CONTRACTOR IS RESPONSIBLE FOR THE PROTECTION OF THE PUBLIC AND ALL CONSTRUCTION PERSONNEL AND MUST COMPLY WITH ALL APPLICABLE OSHA SAFETY REQUIREMENTS THROUGHOUT THE DURATION OF THE WORK.
8. THE CONSTRUCTION DOCUMENTS REPRESENT THE FINISHED STRUCTURE. THEY DO NOT INDICATE THE METHOD OF CONSTRUCTION. THE CONTRACTOR SHALL PROVIDE ALL MEASURES NECESSARY TO PROTECT THE STRUCTURE DURING CONSTRUCTION. SUCH MEASURES SHALL INCLUDE, BUT NOT BE LIMITED TO, BRACING, SHORING FOR LOADS DUE TO DEMOLITION AND CONSTRUCTION EQUIPMENT, ETC. THE ENGINEER OF RECORD SHALL NOT BE RESPONSIBLE FOR THE CONTRACTOR'S MEANS, METHODS, TECHNIQUES, SEQUENCES FOR PROCEDURE OF CONSTRUCTION, OR THE SAFETY PRECAUTIONS AND THE PROGRAMS INCIDENT THERETO (NOR SHALL OBSERVATION VISITS TO THE SITE INCLUDE INSPECTION OF THESE ITEMS).
9. WHERE REFERENCE IS MADE TO VARIOUS TEST STANDARDS FOR MATERIALS, SUCH STANDARDS SHALL BE THE LATEST EDITION AND/OR ADDENDA.
10. ALL STRUCTURAL WORK SHALL BE INSPECTED IN ACCORDANCE WITH THE BUILDING CODE AND ALL LOCAL ORDINANCES. THE OWNER SHALL ENGAGE AN EXPERIENCED, QUALIFIED INSPECTION AGENCY SUBJECT TO THE REVIEW OF THE ENGINEER, TO PERFORM ALL INSPECTION WORK AS NEEDED.
11. THE DOCUMENTS PREPARED BY CSI PROVIDE INFORMATION FOR REPAIRS OF THE BUILDING STRUCTURE ONLY. CONDITIONS ASSOCIATED WITH GLAZING, MECHANICAL, ELECTRICAL, AND PLUMBING SYSTEMS SHALL BE OBSERVED BY THE CONTRACTOR AND ADDRESSED AS NECESSARY TO AS TO MAINTAIN THEIR INTEGRITY DURING THE STRUCTURAL REPAIR WORK.

MATERIAL SPECIFICATIONS

CONCRETE

1. ALL CONCRETE HAS BEEN DESIGNED IN ACCORDANCE WITH THE ACI 318 AND SHALL BE CONSTRUCTED IN ACCORDANCE WITH ACI 301.
2. COMPRESSIVE STRENGTH REQUIRED (UNO): ALL CONCRETE: F'c= 4000 PSI AT 28 DAYS.
3. CONCRETE MIX DESIGNS SHALL BE SUBMITTED FOR THE REVIEW AND APPROVAL OF THE EOR/AOR.
4. MINIMUM COVER FOR REINFORCING SHALL BE AS FOLLOWS:
FOOTINGS AND GRADE BEAMS: 3"
SLABS ON GRADE: CENTERED
ELEVATED SLABS: 2"
ALL OTHER: 2"
5. ALL REINFORCEMENT SHALL CONFORM TO ASTM A615, GRADE 60, AND BE FREE FROM LOOSE CORROSION AND SCALE. ALL WELDED WIRE REINFORCEMENT SHALL CONFORM TO ASTM A185.
6. ALL HOOKS IN REINFORCING BARS SHALL BE ACI STANDARD HOOKS.
7. ALL CONCRETE REINFORCEMENT SHALL BE DETAILED, FABRICATED, LABELED, SUPPORTED, SPACED IN FORMS, AND SECURED IN PLACE IN ACCORDANCE WITH THE PROCEDURES AND REQUIREMENTS OUTLINED IN THE LATEST EDITION OF THE 'MANUAL OF STANDARD PRACTICE FOR DETAILING REINFORCED CONCRETE STRUCTURES', ACI 315.
8. BAR SUPPORTS SHALL BE PLASTIC DIPPED AFTER FABRICATION.
9. ALL REINFORCING SPLICES SHALL CONFORM TO THE REQUIREMENTS OF THE LATEST EDITION OF ACI 318, BUT IN NO CASE SHALL BE LESS THAN 40 BAR DIAMETERS (UNO).
10. ALL WELDED WIRE REINFORCING SHALL BE PLACED IN THE CENTER THIRD OF THE SLAB AND LAPPED (2) MESH PANELS AND TIED SECURELY.
11. WHERE REQUIRED, DOWELS SHALL MATCH SIZE AND NUMBER OF MAIN REINFORCING (UNO).
12. SUPPORT BARS SHALL BE #5 OR GREATER, AND NOT SPACED MORE THAN 48" ON CENTER. A MINIMUM OF (3) SUPPORT BARS AND (3) INDIVIDUAL CHAIRS FOR EACH SUPPORT BAR SHALL BE PROVIDED FOR TOP BARS. SUPPORT BARS AND ENDS OF MAIN REINFORCING SHALL NOT EXTEND MORE THAN 1'-6" PAST THE OUTERMOST CHAIR OR SUPPORT BAR.
13. SLABS ON GRADE: SHALL BE INSTALLED OVER MINIMUM 6 MIL POLYETHYLENE VAPOR BARRIER WITH JOINTS LAPPED 6" AND SEALED OVER CLEAN, COMPACTED EARTH OR FILL WITH APPROVED CHEMICAL SOIL TREATMENT FOR PREVENTION OF SUBTERRANEAN TERMITES.
14. SAWCUTS FOR SLABS ON GRADE W/O REBAR: FOR CONTROLLED CRACKING PROVIDE 1" DEEP SAWCUT INTO SLAB AT MAX 10'X10' GRID W/IN 12 HOURS OF CONCRETE PLACEMENT. CONTACT EOR/AOR FOR ALTERNATIVE METHODS.

CONCRETE RESTORATION

1. SEE "CR" SHEETS FOR SPECIFIC INFORMATION ON CONCRETE RESTORATION.

STEEL

1. ANCHOR BOLTS & THREADED RODS: SHALL BE IN ACCORDANCE WITH ASTM A307 OR ASTM F1554 GRADE 36.
2. WASHERS: SHALL BE IN ACCORDANCE WITH ASTM A 5000 GRADE B.
3. NUTS: SHALL BE IN ACCORDANCE WITH ASTM A563 GRADE A HEX.
4. METAL CONNECTORS: ALL METAL CONNECTORS WHICH ARE EXPOSED TO THE EXTERIOR ENVIRONMENT SHALL BE STAINLESS STEEL. G90 GALVANIZED IS ACCEPTABLE IF CONCEALED WITHIN THE BUILDING ENVELOPE.
5. EPOXY ADHESIVE: SHALL BE EITHER SIMPSON STRONG-TIE "SET" OR USP CIA-GEL 7000 (DUAL CARTRIDGE).
6. ALL METAL STRAPS AND HANGERS SHALL BE STAINLESS STEEL IF EXPOSED TO THE EXTERIOR ENVIRONMENT. G90 HOT-DIPPED GALVANIZED IS ACCEPTABLE IF CONCEALED WITHIN THE BUILDING ENVELOPE.
7. ALL WOOD FASTENERS (NAILS, SCREWS, BOLTS, ETC.) EXPOSED TO THE EXTERIOR ENVIRONMENTS SHALL BE STAINLESS STEEL IN ACCORDANCE WITH ASTM 153 OR BETTER. G90 HOT-DIPPED GALVANIZED IS ACCEPTABLE IF CONCEALED WITHIN THE BUILDING ENVELOPE

COLD FORMED METAL FRAMING REPAIRS

1. THE EXTERIOR WALLS OF THE BUILDING ARE FRAMED WITH METAL STUDS, WITH WOOD STUDS AT THE PATIO DOORS.
2. THERE WILL BE FOUR LEVELS OF METAL STUD REPAIRS TO BE FIELD DETERMINED.
 - a. CLEAN METAL SURFACES AND COAT WITH COLD GALVANIZING COMPOUND.
 - b. CLEAN METAL SURFACES AND COAT WITH COLD GALVANIZING COMPOUND, AND ADD CLIPS TOP AND/OR BOTTOM OF STUDS.
 - c. CLEAN METAL SURFACES AND COAT WITH COLD GALVANIZING COMPOUND, AND ADD CLIPS TOP AND/OR BOTTOM OF STUDS, SPLICE IN SECTIONS OF METAL STUD TO REPAIR DAMAGED AREAS.
 - d. COMPLETE REMOVAL AND REPLACEMENT OF METAL STUD FRAMING.
3. REPLACEMENT METAL STUDS SHALL BE A MINIMUM OF 18 GAGE WITH 1 3/8" FLANGES. MATCH EXISTING STUD THICKNESS.

STRUCTURAL LUMBER

1. ALL STRUCTURAL LUMBER SHALL CONFORM TO THE MOST CURRENT APPLICABLE SPECIFICATIONS OF THE AMERICAN INSTITUTE OF TIMBER CONSTRUCTION.
2. LUMBER GRADES
ALL DIMENSION LUMBER: #2 SOUTHERN YELLOW PINE
3. ALL STRUCTURAL LUMBER SHALL BE IN ACCORDANCE WITH THE NATIONAL DESIGN SPECIFICATION FOR WOOD CONSTRUCTION BY AMERICAN FOREST & PAPER ASSOCIATION.
4. ALL LUMBER SHALL COMPLY WITH PS 20 "AMERICAN SOFTWOOD LUMBER STANDARD" AND WITH THE APPLICABLE RULE OF INSPECTION AGENCIES CERTIFIED BY AMERICAN LUMBER STANDARD. FACTORY MARK EACH PIECE OF LUMBER WITH GRADE STAMP OF INSPECTION AGENCY EVIDENCING COMPLIANCE WITH GRADING RULE REQUIREMENTS.
5. ALL NEW STUD WALLS SHALL BE CONTINUOUSLY BRIDGED AT MID-HEIGHT AND AT ALL UNSUPPORTED HORIZONTAL PLYWOOD WALL SHEATHING JOINTS WITH SOLID WOOD BLOCKING.
6. ALL NEW STUD WALLS SHALL HAVE 2X6 STUDS AT 16" O.C. MAX.
7. NO CUTS, HOLES, OR COPES REQUIRED FOR OTHER TRADES IN STRUCTURAL WOOD FRAMING WILL BE PERMITTED WITHOUT PRIOR REVIEW AND APPROVAL OF ENGINEER AND ARCHITECT.
8. PRESSURE TREAT WITH WATER-BORNE PRESERVATIVES ALL LUMBER FOR EXTERIOR WALLS, INCLUDING SILL PLATES, TOP PLATES, STUDS & WALL SHEATHING. PRESSURE TREAT WITH SODIUM BORATE (DOT - DISODIUM OCTABORATE TETRA HYDRATE). IF HOWEVER, ACQ OR NON-DOT BORATE PT IS USED, ALL ATTACHED FASTENERS SHALL BE G90 HOT-DIPPED GALVANIZED. IF ACZA PT IS USED, ALL ATTACHED FASTENERS SHALL BE STAINLESS STEEL.
9. PROVIDE NAILING PATTERN IN COMPLIANCE WITH FBC RECOMMENDED FASTENING SCHEDULE WHEN JOINING TWO OR MORE FRAMING MEMBERS.
10. ALTERNATE CONNECTION DETAILS MAY BE USED IF SUCH DETAILS ARE SUBMITTED TO THE ENGINEER FOR REVIEW AND APPROVAL. HOWEVER, THE ENGINEER SHALL BE THE SOLE JUDGE OF ACCEPTANCE AND THE CONTRACTOR'S BID SHALL ANTICIPATE THE USE OF THOSE SPECIFIED DETAILS SHOWN ON THE DRAWINGS THE CONTRACTOR IS RESPONSIBLE FOR THE DESIGN OF SUCH ALTERNATE DETAILS WHICH HE PROPOSES.

PLYWOOD SHEATHING

1. ALL PLYWOOD SHALL CONFORM TO THE MOST CURRENT APPLICABLE SPECIFICATION AND SUPPLEMENTS OF THE AMERICAN PLYWOOD ASSOCIATION (APA).
2. EACH PANEL SHALL BE IDENTIFIED WITH THE APPROPRIATE TRADEMARK OF THE APA AND SHALL MEET THE REQUIREMENTS OF THE LATEST EDITION OF THE APA PERFORMANCE STANDARDS.
3. PANEL THICKNESS, GRADE AND SPAN RATING SHALL BE EQUAL TO THAT SHOWN ON THE DRAWINGS. THE CENTER-TO-CENTER SPACING IN INCHES SHALL NOT EXCEED THE SPAN RATING STAMPED ON THE PANELS. INSTALLATION OF THE PANELS SHALL BE IN ACCORDANCE WITH THE RECOMMENDATIONS OF APA.
4. ALL PANELS WHICH HAVE ANY EDGE OR FACE PERMANENTLY EXPOSED TO THE WEATHER SHALL BE CLASSED EXTERIOR. EXCEPT OPEN SOFFITS OR ROOF SHEATHING EXPOSED ON THE UNDERSIDE MAY BE CLASSED EXPOSURE 1.
5. ALL PLYWOOD PANEL END JOINTS SHALL OCCUR OVER SUPPORTS AND SHALL BE STAGGERED ONE HALF PANEL LENGTH FROM ADJACENT PANELS. PROVIDE 1/8 INCH SPACE AT PANEL ENDS AND EDGES.
6. ALL PLYWOOD FLOOR SHEATHING SHALL BE 23/32-INCH APA RATED TONGUE AND GROOVE SHEATHING, 32/16 SPAN RATING. EXPOSURE 1. INSTALL WITH LONG DIMENSION OF PANEL ACROSS THREE OR MORE SUPPORTS. ALL PANELS SHALL BE NAILED AS INDICATED BELOW. ALL FLOOR SHEATHING FOR OUTER DECKS SHALL BE PRESSURE TREATED.
7. ALL WALL SHEATHING (IF NEEDED) SHALL BE 15/32-INCH APA RATED SHEATHING, EXPOSURE 1. INSTALL WITH LONG DIMENSION OF PANEL ACROSS THREE OR MORE SUPPORTS. PROVIDE BLOCKING AT ALL JOINTS. ALL PANELS SHALL BE NAILED AS INDICATED BELOW.
 - A. FLOOR: GLUE AND NAIL WITH 10d RINGSHANK NAILS AT 6" O.C. AT ALL EDGES, ENDS AND BLOCKING, AND AT 6" O.C. AT ALL INTERMEDIATE SUPPORTS. (TYP UNO). PROVIDE STAINLESS STEEL NAILS AT EXTERIOR DECKS.
 - B. WALL: 8d COMMON NAILS AT MAX 4" O.C. AT ALL EDGES, ENDS AND BLOCKING, AND AT 12" O.C. AT ALL INTERMEDIATE SUPPORTS.(TYP UNO)
8. SHEATHING NAILING PATTERNS

DESIGN CRITERIA

CODE: 2017 FLORIDA BUILDING CODE (FBC)
WIND DESIGN CRITERIA PER FBC 2017,
SECTION 1609, & ASCE 7-10
BASIC WIND SPEED: 130 MPH (3-SEC GUST)
RISK CATEGORY TYPE II BUILDING
IMPORTANCE FACTOR: 1.0
MEAN ROOF HEIGHT: 35'-0"
EXPOSURE CATEGORY: D
ENCLOSURE CLASSIFICATION: ENCLOSED
INTERNAL PRESSURE COEF: ±0.18
ROOF SLOPE: (0":12") TYP
EDGE STRIP = 4'-0" (C&C)

ASCE 7-10, COMPONENTS AND CLADDING
(FOR 10 SF OR LESS EFFECTIVE AREA)
WALL
INTERIOR ZONE: -34.5/+31.8 PSF
END ZONE: -53.4/+29.1 PSF
ROOF
INTERIOR ZONE: -31.8/+18.3 PSF
END ZONE: -53.4/+18.3 PSF
CORNER ZONE: -80.4/+18.3 PSF
ROOF DESIGN LIVE LOAD: 20 PSF
ALL DESIGN PER ASD METHOD

CONSTRUCTION SOLUTIONS, INC.
961687 GATEWAY BLVD - SUITE 101B
AMELIA ISLAND, FLORIDA 32034
PHONE: (904) 261-8703 FAX: (877) 808-1839
FLORIDA CERTIFICATE OF AUTHORIZATION NO. 26752



REPAIRS AND RENOVATIONS
FOR
BEACHCOMBER I CONDOMINIUMS
JACKSONVILLE BEACH, FLORIDA

STRUCTURAL NOTES

REV:	DATE:	DESC:

NOT FOR
CONSTRUCTION -
FOR REVIEW
BID SET

JEFFREY B. SELLERS
FL PE # 68313
3/1/18

DRAWING SHEET:
S1

BID SET

THIS DRAWING IS THE PROPERTY OF CONSTRUCTION SOLUTIONS, INC. ANY USE OR REPRODUCTION WITHOUT THE EXPRESSED WRITTEN CONSENT OF CONSTRUCTION SOLUTIONS, INC. IS PROHIBITED. ALL RIGHTS OF DESIGN AND INVENTION ARE EXPRESSLY RESERVED.

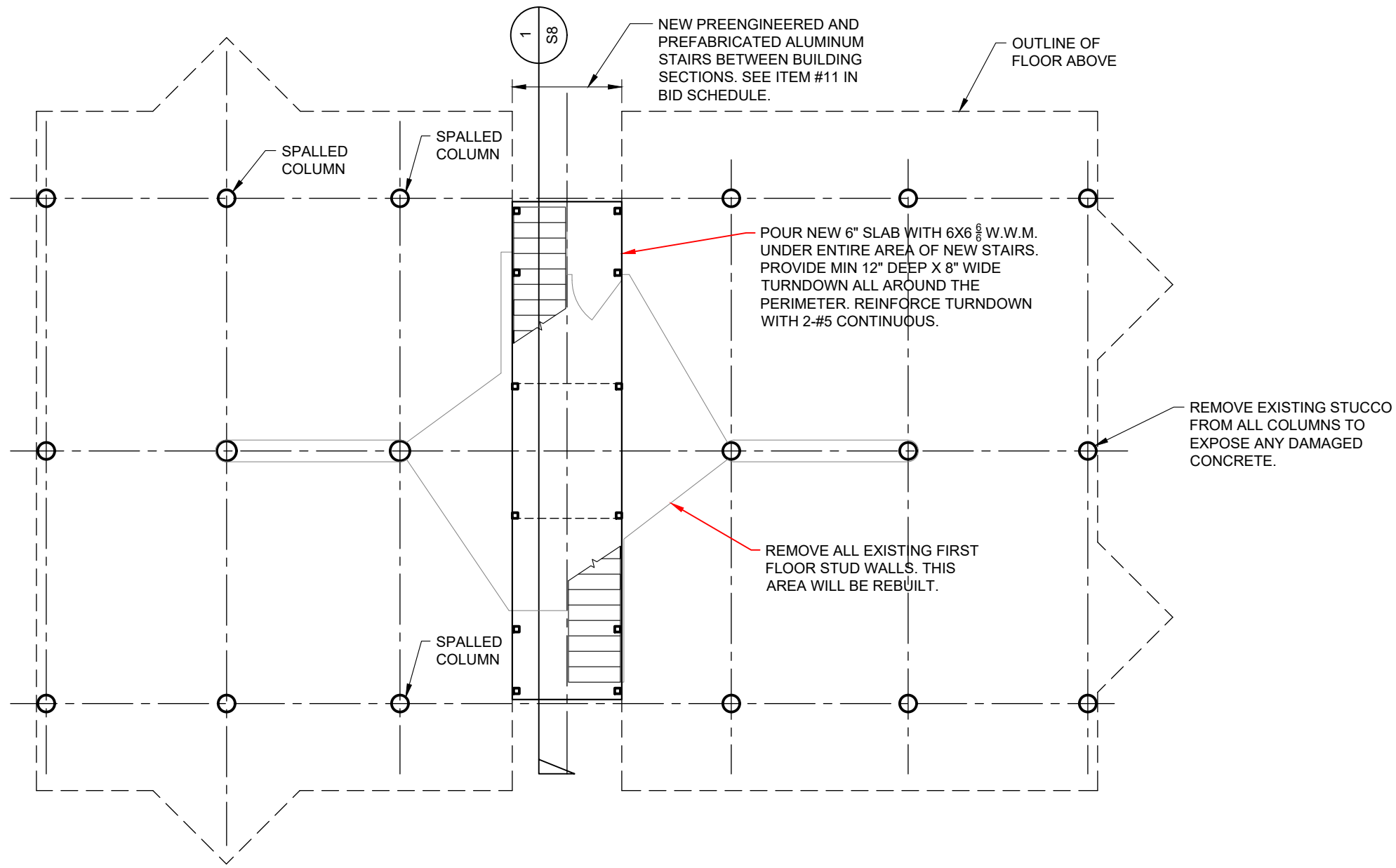

FIRST FLOOR PLAN

SCALE: $\frac{1}{8}'' = 1'-0''$

CONSTRUCTION SOLUTIONS, INC.
 961687 GATEWAY BLVD - SUITE 101B
 AMELIA ISLAND, FLORIDA 32034
 PHONE: (904) 261-8703 FAX: (877) 808-1839
 FLORIDA CERTIFICATE OF AUTHORIZATION NO. 26752



REPAIRS AND RENOVATIONS
 FOR
BEACHCOMBER I CONDOMINIUMS
 JACKSONVILLE BEACH, FLORIDA

FIRST FLOOR

REV:	DATE:	DESC:

NOT FOR CONSTRUCTION - FOR REVIEW FOR BID SET

JEFFREY B. SELLERS
 FL PE # 68313
 3/1/18

DRAWING SHEET:
S2

BID SET

THIS DRAWING IS THE PROPERTY OF CONSTRUCTION SOLUTIONS, INC. ANY USE OR REPRODUCTION WITHOUT THE EXPRESSED WRITTEN CONSENT OF CONSTRUCTION SOLUTIONS, INC. IS PROHIBITED. ALL RIGHTS OF DESIGN AND INVENTION ARE EXPRESSLY RESERVED.

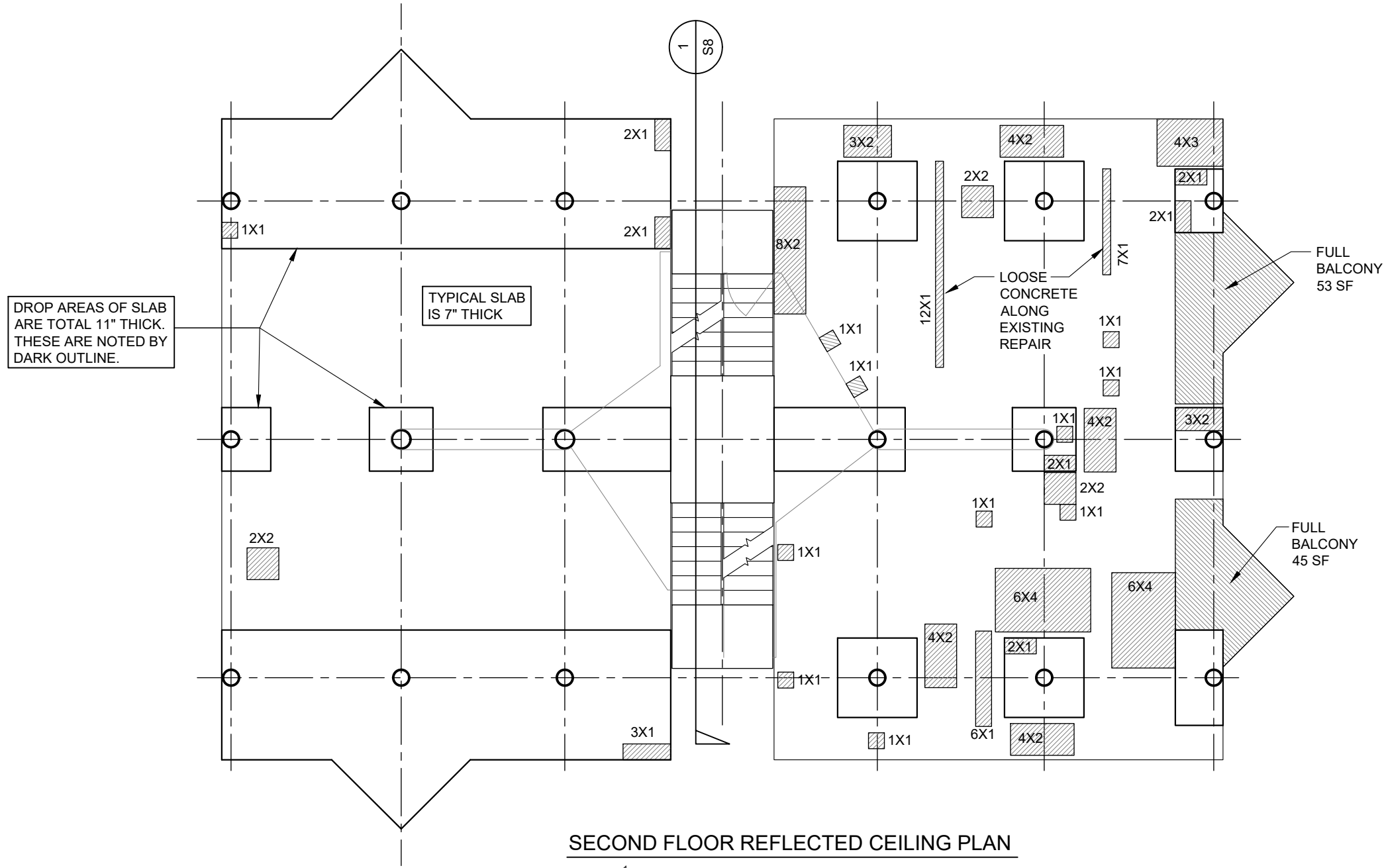

SECOND FLOOR REFLECTED CEILING PLAN

SCALE: $\frac{1}{8}'' = 1'-0''$

- NOTES:
1. SPALLED AREAS OF SLAB ARE NOTED APPROXIMATELY FOR BIDDING PURPOSES.
 2. SLAB SHALL BE SOUNDED BY CONTRACTOR TO DETERMINE FINAL REPAIR AREAS.

CONSTRUCTION SOLUTIONS, INC.
 961687 GATEWAY BLVD - SUITE 101B
 AMELIA ISLAND, FLORIDA 32034
 PHONE: (904) 261-8703 FAX: (877) 808-1839
 FLORIDA CERTIFICATE OF AUTHORIZATION NO. 26752



REPAIRS AND RENOVATIONS
 FOR
 BEACHCOMBER I CONDOMINIUMS
 JACKSONVILLE BEACH, FLORIDA

SECOND FLOOR
 REFLECTED CEILING

REV.	DATE:	DESC:

NOT FOR
 CONSTRUCTION -
 FOR REVIEW
 BID SET

JEFFREY B. SELLERS
 FL PE # 68313
 3/1/18

BID SET

DRAWING SHEET:
S3

THIS DRAWING IS THE PROPERTY OF CONSTRUCTION SOLUTIONS, INC. ANY USE OR REPRODUCTION WITHOUT THE EXPRESSED WRITTEN CONSENT OF CONSTRUCTION SOLUTIONS, INC. IS PROHIBITED. ALL RIGHTS OF DESIGN AND INVENTION ARE EXPRESSLY RESERVED.

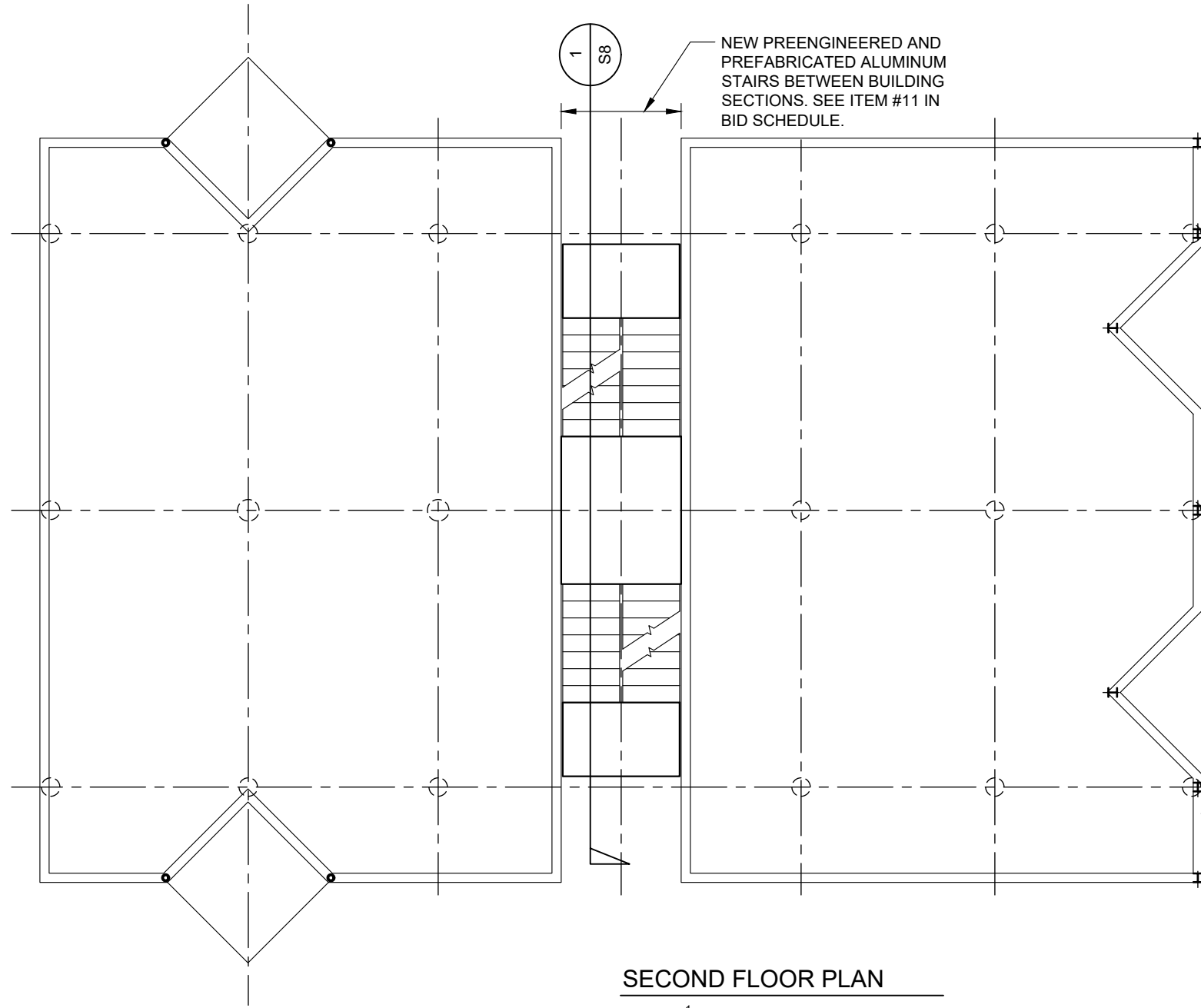

NEW PREENGINEERED AND PREFABRICATED ALUMINUM STAIRS BETWEEN BUILDING SECTIONS. SEE ITEM #11 IN BID SCHEDULE.

- ALL EXISTING CONCRETE SLAB BALCONIES TO BE RESTORED (AS REQD).
- DO ALL CONCRETE RESTORATION AS DETERMINED BY SPALLED CONCRETE BEFORE WORK ABOVE SLAB.
 - CLEAN AND PAINT EXISTING STEEL BEAMS AND COLUMNS. REPAIR AS NEEDED.
 - STRIP WALLS DOWN TO STUDS AND REPLACE DAMAGED WOOD OR METAL STUD FRAMING, AND SHEATHING.
 - PROVIDE NEW FLASHING AND WATERPROOFING ON FLOOR AND WALLS.
 - REPLACE SLIDING DOORS
 - NEW WRB AND STUCCO ON WALLS
 - NEW FLOOR FINISH
 - NEW HANDRAILS.

- ALL EXISTING EXTERIOR STUD WALLS TO BE RESTORED (AS REQD).
- STRIP WALLS DOWN TO STUDS AND REPLACE DAMAGED WOOD OR METAL STUD FRAMING, AND SHEATHING.
 - CLEAN AND PAINT EXISTING STEEL BEAMS AND COLUMNS. REPAIR AS NEEDED.
 - PROVIDE NEW FLASHING AND WATERPROOFING ON FLOOR AND WALLS.
 - NEW WRB AND STUCCO ON WALLS

SECOND FLOOR PLAN

SCALE: 1/8" = 1'-0"

CONSTRUCTION SOLUTIONS, INC.
 961687 GATEWAY BLVD - SUITE 101B
 AMELIA ISLAND, FLORIDA 32034
 PHONE: (904) 261-8703 FAX: (877) 808-1839
 FLORIDA CERTIFICATE OF AUTHORIZATION NO. 26752



REPAIRS AND RENOVATIONS
 FOR
 BEACHCOMBER I CONDOMINIUMS
 JACKSONVILLE BEACH, FLORIDA

SECOND FLOOR

REV:	DATE:	DESC:

NOT FOR
 CONSTRUCTION -
 FOR REVIEW
 FOR BID SET

JEFFREY B. SELLERS
 FL PE # 68313
 3/1/18

DRAWING SHEET:
S4

BID SET

THIS DRAWING IS THE PROPERTY OF CONSTRUCTION SOLUTIONS, INC. ANY USE OR REPRODUCTION WITHOUT THE EXPRESSED WRITTEN CONSENT OF CONSTRUCTION SOLUTIONS, INC. IS PROHIBITED. ALL RIGHTS OF DESIGN AND INVENTION ARE EXPRESSLY RESERVED.

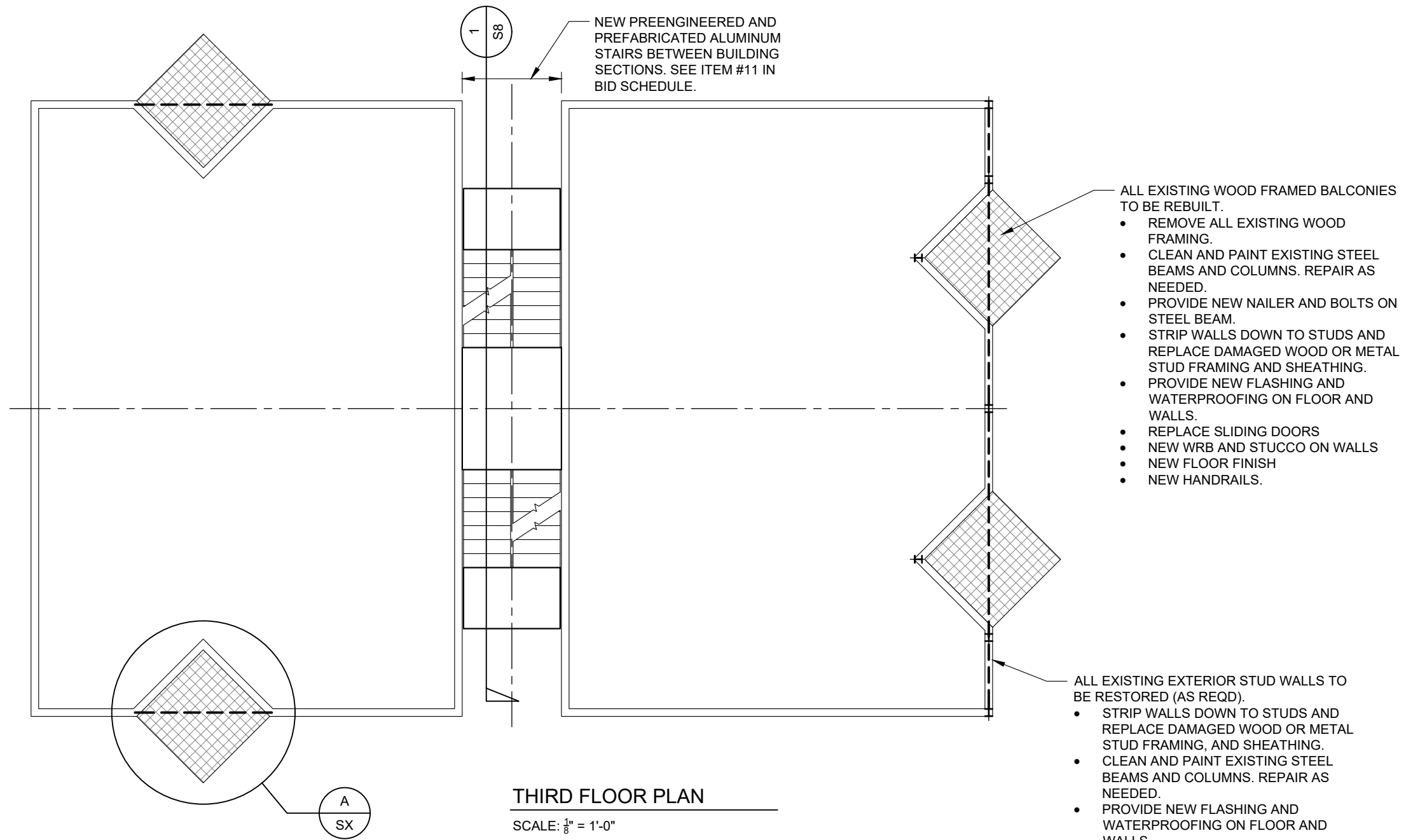

THIRD FLOOR PLAN

SCALE: $\frac{1}{8}" = 1'-0"$



CONSTRUCTION SOLUTIONS, INC.
961687 GATEWAY BLVD - SUITE 101B
AMELIA ISLAND, FLORIDA 32034
PHONE: (904) 261-8703 FAX: (877) 808-1839
FLORIDA CERTIFICATE OF AUTHORIZATION NO. 26752

REPAIRS AND RENOVATIONS
FOR
BEACHCOMBER I CONDOMINIUMS
JACKSONVILLE BEACH, FLORIDA

THIRD FLOOR

REV:	DATE:	DESC:

NOT FOR
CONSTRUCTION -
FOR REVIEW
FOR BID SET

JEFFREY B. SELLERS
FL PE # 68313
3/1/18

DRAWING SHEET:
S5

BID SET

THIS DRAWING IS THE PROPERTY OF CONSTRUCTION SOLUTIONS, INC. ANY USE OR REPRODUCTION WITHOUT THE EXPRESSED WRITTEN CONSENT OF CONSTRUCTION SOLUTIONS, INC. IS PROHIBITED. ALL RIGHTS OF DESIGN AND INVENTION ARE EXPRESSLY RESERVED.

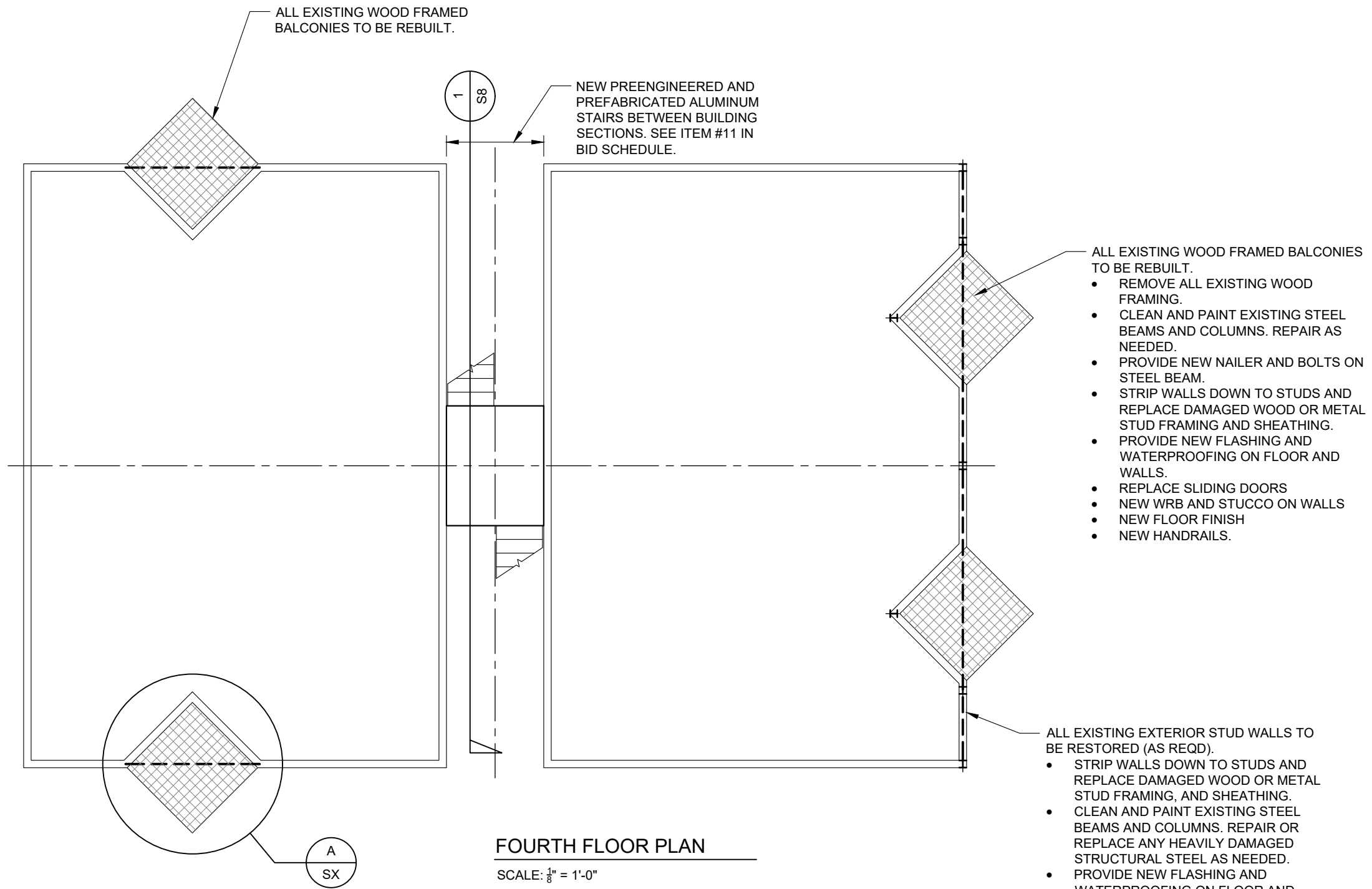

FOURTH FLOOR PLAN

SCALE: 1/8" = 1'-0"

CONSTRUCTION SOLUTIONS, INC.
 961687 GATEWAY BLVD - SUITE 101B
 AMELIA ISLAND, FLORIDA 32034
 PHONE: (904) 261-8703 FAX: (877) 808-1839
 FLORIDA CERTIFICATE OF AUTHORIZATION NO. 26752



REPAIRS AND RENOVATIONS
 FOR
BEACHCOMBER I CONDOMINIUMS
 JACKSONVILLE BEACH, FLORIDA

FOURTH FLOOR

REV.	DATE	DESC.

NOT FOR CONSTRUCTION - FOR REVIEW BID SET

JEFFREY B. SELLERS
 FL PE # 68313
 3/1/18

DRAWING SHEET:
S6

BID SET

THIS DRAWING IS THE PROPERTY OF CONSTRUCTION SOLUTIONS, INC. ANY USE OR REPRODUCTION WITHOUT THE EXPRESSED WRITTEN CONSENT OF CONSTRUCTION SOLUTIONS, INC. IS PROHIBITED. ALL RIGHTS OF DESIGN AND INVENTION ARE EXPRESSLY RESERVED.

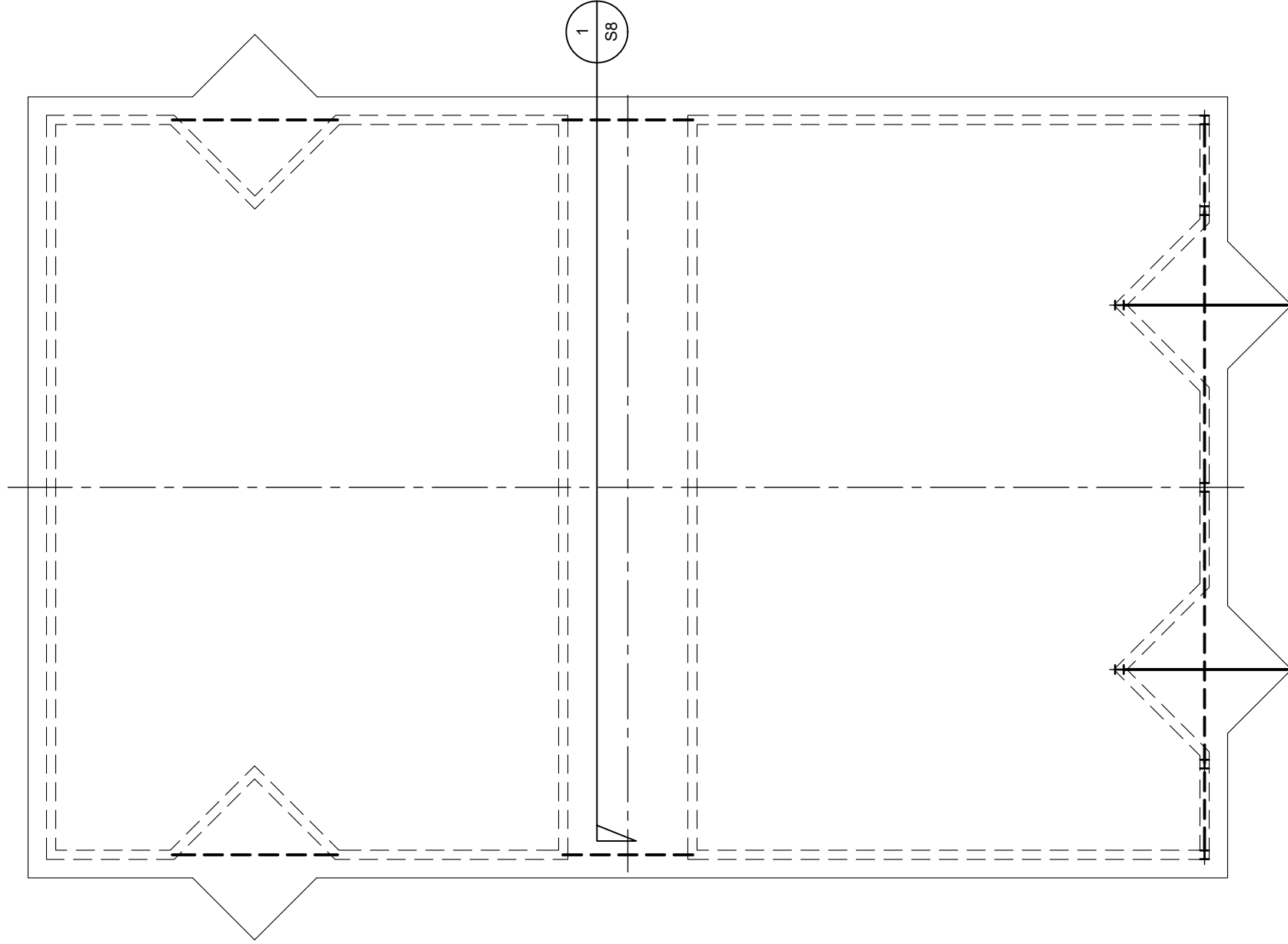

ROOF PLAN

SCALE: $\frac{1}{8}" = 1'-0"$

NOTE: ROOF PLAN IS SHOWN FOR REFERENCE ONLY. NO WORK IS EXPECTED ON THE ROOF.

BID SET

NOT FOR CONSTRUCTION - FOR REVIEW - BID SET
JEFFREY B. SELLERS
FL PE # 68313
3/1/18

REV:	DATE:	DESC:

ROOF

REPAIRS AND RENOVATIONS
FOR
BEACHCOMBER I CONDOMINIUMS
JACKSONVILLE BEACH, FLORIDA



CONSTRUCTION SOLUTIONS, INC.
961687 GATEWAY BLVD - SUITE 101B
AMELIA ISLAND, FLORIDA 32034
PHONE: (904) 261-8703 FAX: (877) 808-1839
FLORIDA CERTIFICATE OF AUTHORIZATION NO. 26752

DRAWING SHEET:
S7

THIS DRAWING IS THE PROPERTY OF CONSTRUCTION SOLUTIONS, INC. ANY USE OR REPRODUCTION WITHOUT THE EXPRESSED WRITTEN CONSENT OF CONSTRUCTION SOLUTIONS, INC. IS PROHIBITED. ALL RIGHTS OF DESIGN AND INVENTION ARE EXPRESSLY RESERVED.

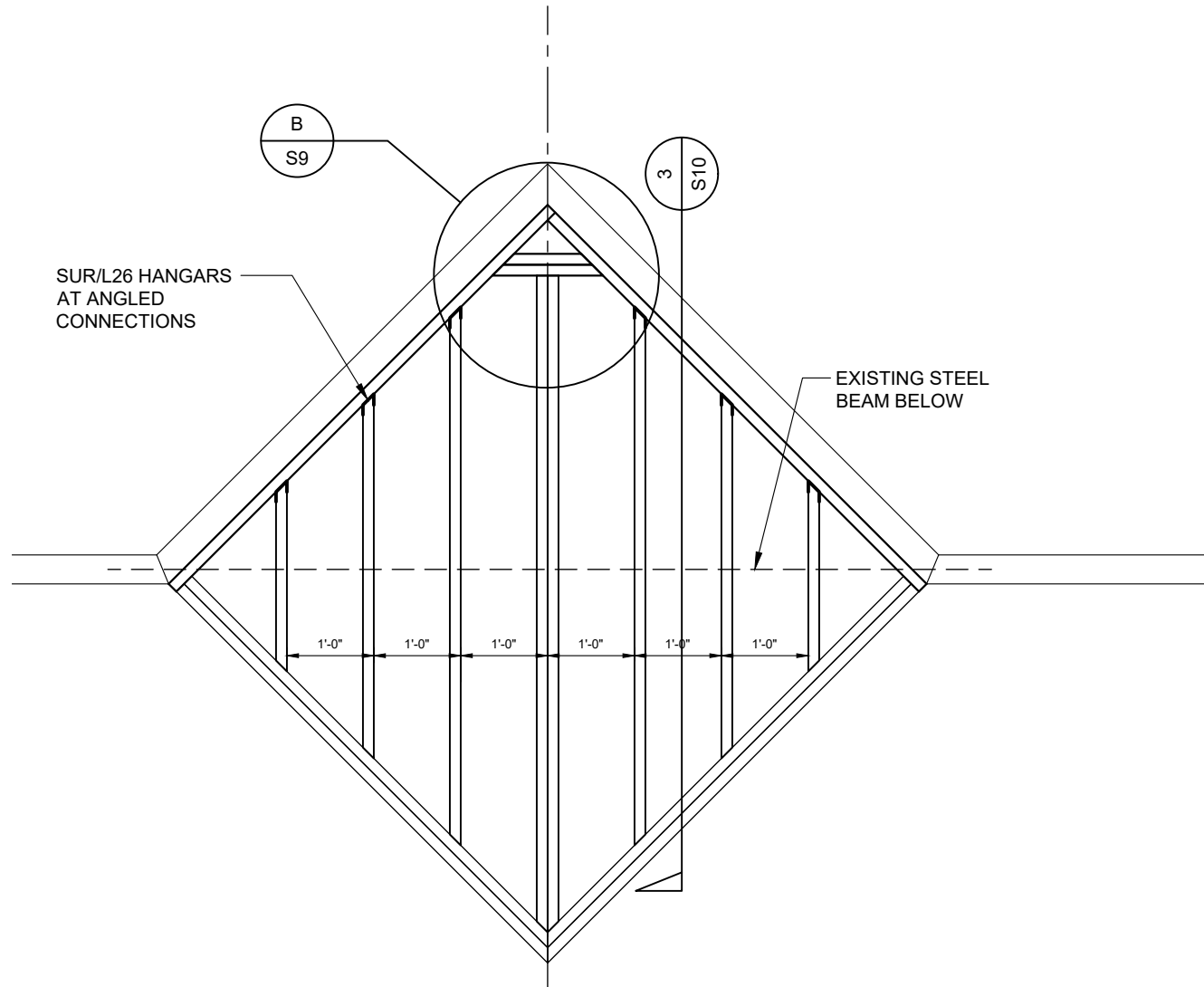

A
S9
PARTIAL PLAN AT BALCONY
SCALE: $\frac{1}{2}$ " = 1'-0"

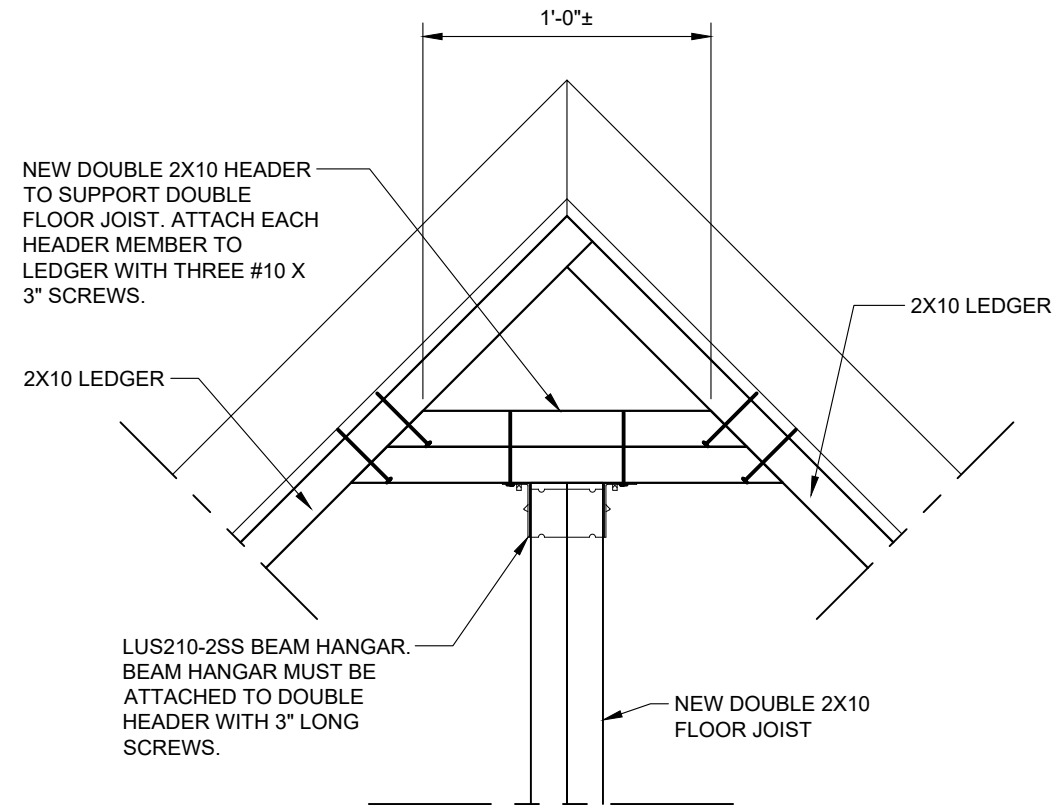

B
S9
DETAIL
SCALE: $1\frac{1}{2}$ " = 1'-0"

CONSTRUCTION SOLUTIONS, INC.
961687 GATEWAY BLVD - SUITE 101B
AMELIA ISLAND, FLORIDA 32034
PHONE: (904) 261-8703 FAX: (877) 808-1839
FLORIDA CERTIFICATE OF AUTHORIZATION NO. 26752



REPAIRS AND RENOVATIONS
FOR
BEACHCOMBER I CONDOMINIUMS
JACKSONVILLE BEACH, FLORIDA

BALCONY PLAN

REV:	DATE:	DESC:

NOT FOR
CONSTRUCTION -
FOR REVIEW
BID SET

JEFFREY B. SELLERS
FL PE # 68313
3/1/18

DRAWING SHEET:

S9

BID SET

THIS DRAWING IS THE PROPERTY OF CONSTRUCTION SOLUTIONS, INC. ANY USE OR REPRODUCTION WITHOUT THE EXPRESSED WRITTEN CONSENT OF CONSTRUCTION SOLUTIONS, INC. IS PROHIBITED. ALL RIGHTS OF DESIGN AND INVENTION ARE EXPRESSLY RESERVED.

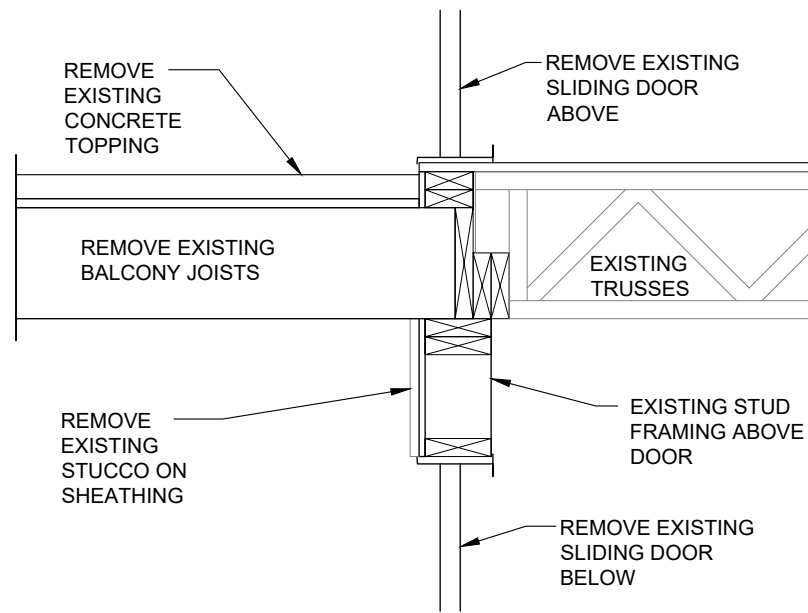

1
SECTION AT SLIDING DOOR - EXISTING CONDITIONS
S10 SCALE: NONE

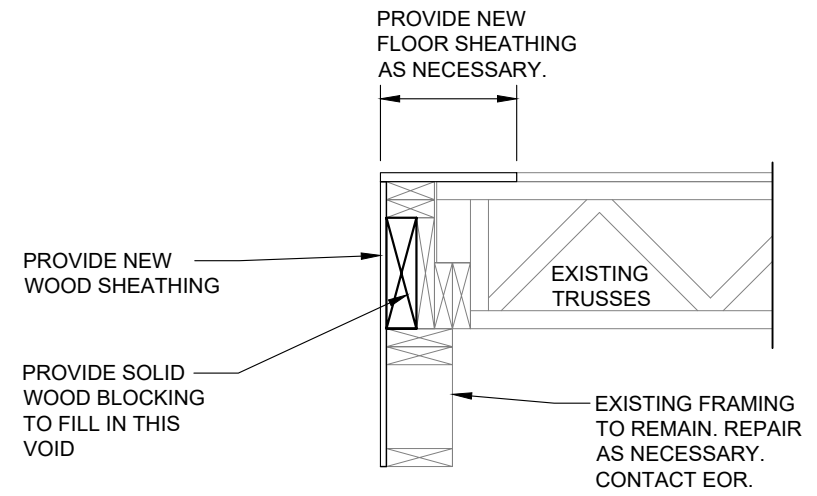

2
SECTION AT SLIDING DOOR - ADDED FRAMING
REQUIRED BEFORE REBUILDING PATIO
S10 SCALE: NONE

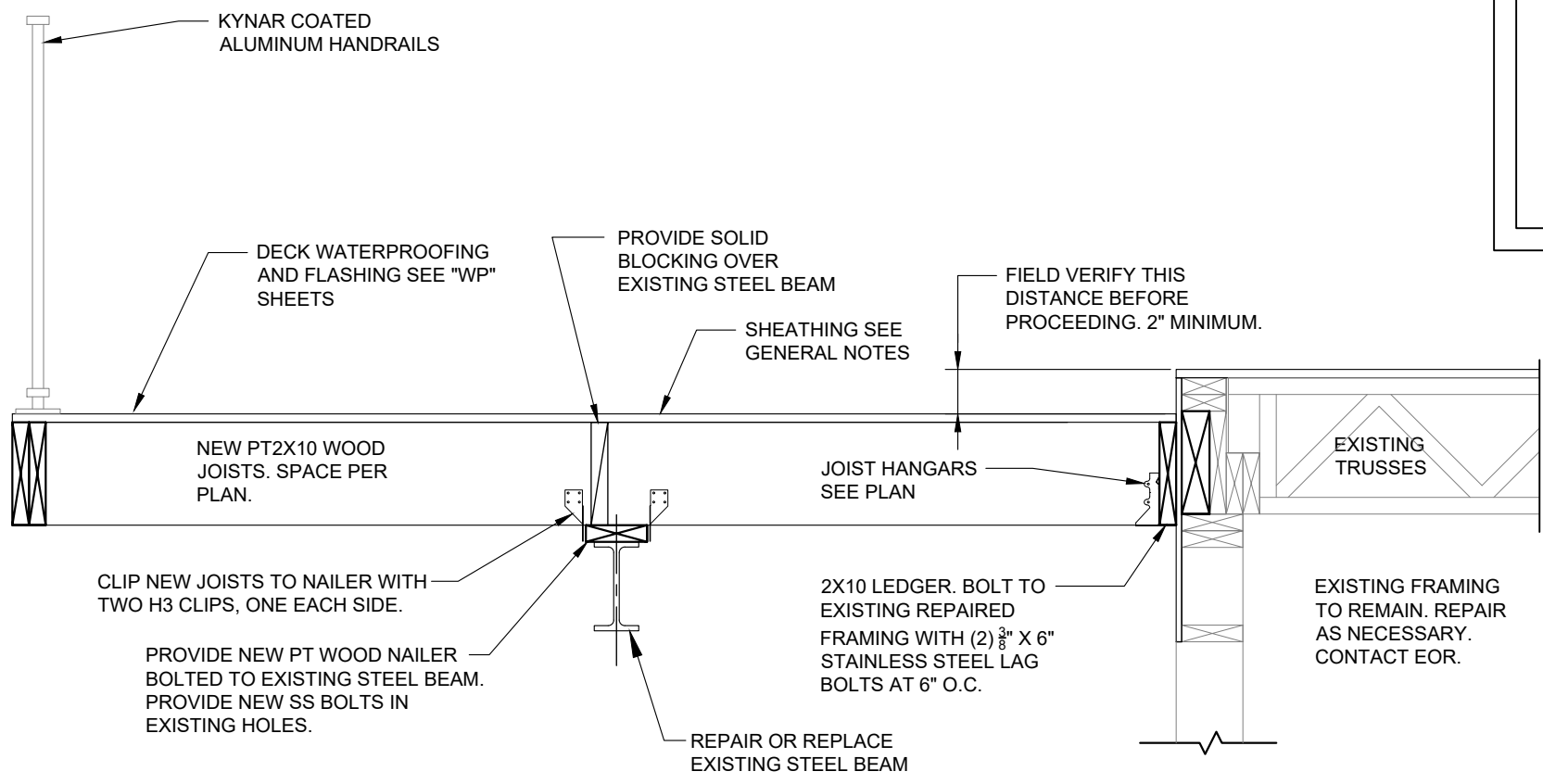

3
REBUILT PATIO SECTION
S10 SCALE: $\frac{3}{4}$ " = 1'-0"

NOTE: DO NOT REBUILD PATIO UNTIL ALL REPAIRS HAVE BEEN MADE TO THE BUILDING WALL.

NOTES THIS SHEET:

- SECTION 1 SHOWS EXISTING CONDITIONS AND ITEMS FOR DEMO.
- SECTION 2 SHOWS ADDED BLOCKING PRIOR TO REBUILDING BALCONY.
- SECTION 3 SHOWS FINAL BALCONY CONFIGURATION.

CONSTRUCTION SOLUTIONS, INC.
961687 GATEWAY BLVD - SUITE 101B
AMELIA ISLAND, FLORIDA 32034
PHONE: (904) 261-8703 FAX: (877) 808-1839
FLORIDA CERTIFICATE OF AUTHORIZATION NO. 26752



REPAIRS AND RENOVATIONS
FOR
BEACHCOMBER I CONDOMINIUMS
JACKSONVILLE BEACH, FLORIDA

REPAIR DETAILS

REV:	DATE:	DESC:

NOT FOR
CONSTRUCTION -
FOR REVIEW
BID SET

JEFFREY B. SELLERS
FL PE # 68313
3/1/18

DRAWING SHEET:
S10

BID SET

THIS DRAWING IS THE PROPERTY OF CONSTRUCTION SOLUTIONS, INC. ANY USE OR REPRODUCTION WITHOUT THE EXPRESSED WRITTEN CONSENT OF CONSTRUCTION SOLUTIONS, INC. IS PROHIBITED. ALL RIGHTS OF DESIGN AND INVENTION ARE EXPRESSLY RESERVED.

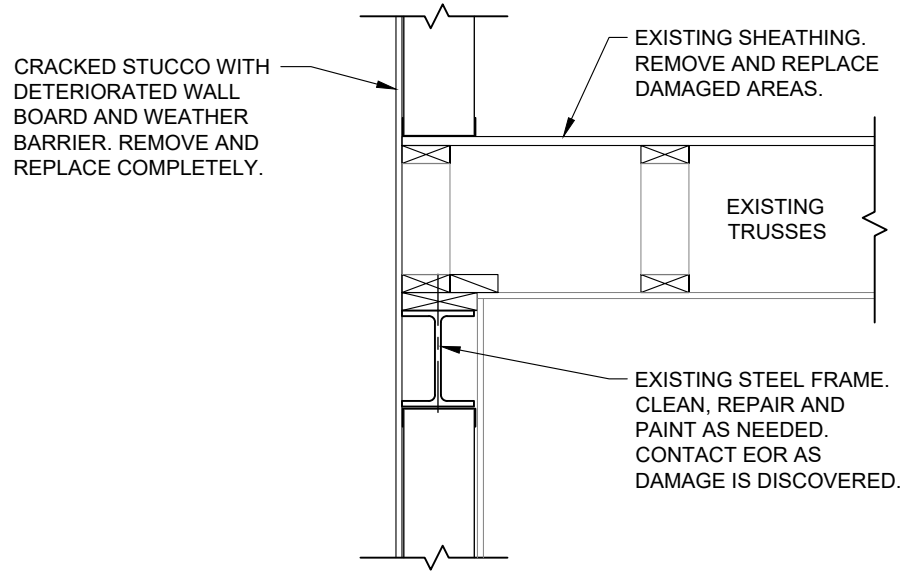

1
S11 SECTION AT THIRD/FOURTH FLOORS METAL STUDS
SCALE: NONE

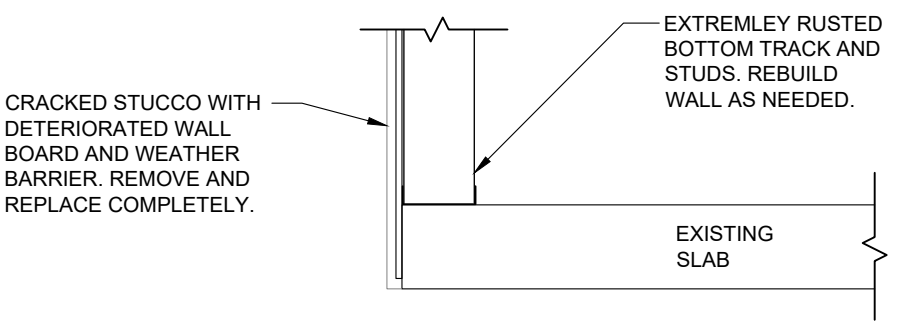

2
S11 SECTION AT SECOND FLOOR - METAL STUDS
SCALE: NONE

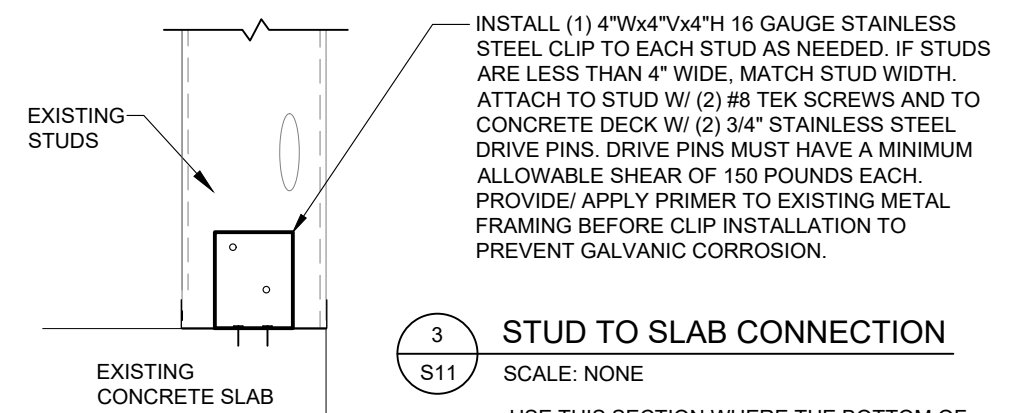

3
S11 STUD TO SLAB CONNECTION
SCALE: NONE
USE THIS SECTION WHERE THE BOTTOM OF THE EXISTING STUD IS DAMAGED LESS THAN 2" ABOVE THE EXISTING SLAB

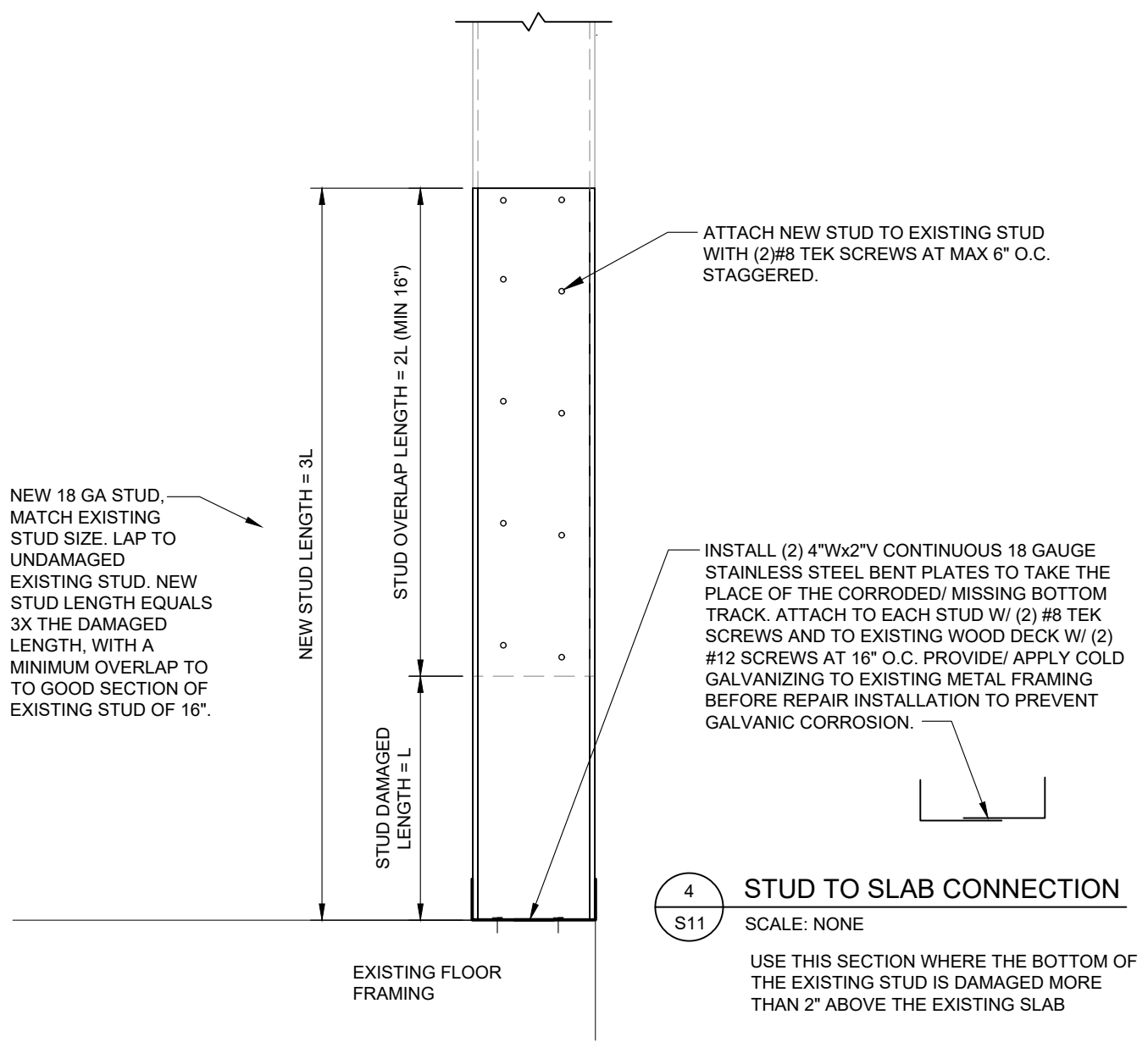

4
S11 STUD TO SLAB CONNECTION
SCALE: NONE
USE THIS SECTION WHERE THE BOTTOM OF THE EXISTING STUD IS DAMAGED MORE THAN 2" ABOVE THE EXISTING SLAB

CONSTRUCTION SOLUTIONS, INC.
961687 GATEWAY BLVD - SUITE 101B
AMELIA ISLAND, FLORIDA 32034
PHONE: (904) 261-8703 FAX: (877) 808-1839
FLORIDA CERTIFICATE OF AUTHORIZATION NO. 26752

REPAIRS AND RENOVATIONS
FOR
BEACHCOMBER I CONDOMINIUMS
JACKSONVILLE BEACH, FLORIDA

REPAIR DETAILS

REV:	DATE:	DESC:

NOT FOR CONSTRUCTION - FOR REVIEW BID SET

JEFFREY B. SELLERS
FL PE # 68313
3/1/18

DRAWING SHEET:
S11

BID SET

THIS DRAWING IS THE PROPERTY OF CONSTRUCTION SOLUTIONS, INC. ANY USE OR REPRODUCTION WITHOUT THE EXPRESSED WRITTEN CONSENT OF CONSTRUCTION SOLUTIONS, INC. IS PROHIBITED. ALL RIGHTS OF DESIGN AND INVENTION ARE EXPRESSLY RESERVED.

CONCRETE REPAIR

1. SEE SPECIFICATIONS FOR DIRECTIONS ON SOUNDING, CONCRETE REMOVAL, SURFACE PREPARATION, PLACEMENT OF REPAIR MATERIAL AND ALL OTHER REPAIR REQUIREMENTS.
2. THE LIMITS OF ANTICIPATED DEMOLITION AND THE PROPOSED REPAIR METHODS ARE SHOWN IN DETAILS
3. FOLLOW ALL ICRI GUIDELINES
4. CONCRETE REPAIR CONTRACTOR SHALL BE A MEMBER OF THE LOCAL ICRI FIRST COAST CHAPTER.
5. ALL NOTES APPLY TO ALL SECTIONS EVEN IF NOT NOTED SPECIFICALLY ON THE SECTION.

DEMOLITION

1. PERFORM SOUNDING OF CONCRETE SURFACES AS REQUIRED BY THE PROJECT SPECIFICATIONS. MARK ALL SPALLED AREAS WITH A PAINT OUTLINE.
2. DEMOLISH CONCRETE TO AT LEAST THE LIMITS MARKED PER NOTE #1 ABOVE IN ACCORDANCE WITH THE SECTIONS AND TYPICAL DETAILS AND TO A MINIMUM DEPTH OF 1 1/2" OR TO SOUND CONCRETE WHICHEVER IS GREATER. FINAL DEMOLISHED AREA SHALL BE APPROXIMATELY RECTANGULAR WITH STRAIGHT SIDES, LEVEL SURFACE AND SQUARE-CUT CORNERS. THIS MAY NECESSITATE REMOVAL OF SOUND CONCRETE IN SOME AREAS TO CONFORM TO THE REQUIREMENTS OF THE SECTIONS AND TYPICAL DETAILS, THE SURFACE OF THE SOUND CONCRETE SHALL BE DETERMINED AND APPROVED IN ACCORDANCE WITH THE REQUIREMENTS OF THE PROJECT SPECIFICATIONS.
3. AT THE PERIMETER OF THE DEMOLITION, THE SURFACE NORMAL TO THE FACE OF MEMBERS SHALL BE SAW-CUT APPROXIMATELY STRAIGHT FOR A MINIMUM DEPTH OF 1/2" OR TO THE DEPTH OF THE EXISTING REINFORCING STEEL WHICHEVER IS LESS. TAKE EXTREME CARE TO AVOID CUTTING REBAR AND TENDONS. SQUARE CUT CORNERS IN PATTERNS AS SIMPLE AS POSSIBLE.
4. 1" MIN. CLEARANCE BETWEEN EXPOSED REBAR AND SOUND CONCRETE IF REBAR IS EXPOSED DURING REMOVAL OF UNSOUND CONCRETE.
5. THE FINAL DEMOLISHED SURFACE AT ANY LOCATION SHALL BE REASONABLY SMOOTH WITH NO SHARP PROJECTIONS.
6. DO NOT DAMAGE OR CUT EXISTING REINFORCING STEEL DURING DEMOLITION, WITHOUT DIRECTION FROM THE STRUCTURAL ENGINEER.
7. PRIOR TO PLACING PATCH MATERIAL, SANDBLAST OR WATERBLAST EXISTING SURFACES AND EXPOSED REINFORCING SURFACES. REINFORCING SHALL BE CLEAN, SOUND, AND FREE OF CONTAMINANTS.
8. INCLUDE BONDING ADDITIVE IN REPAIR MORTAR OR COAT CONCRETE AND REINFORCING WITH COMPATIBLE PRIMER AND/OR BONDING AGENT.

SPALL REPAIR

1. ALL REINFORCED CONCRETE WORK SHALL BE IN CONFORMANCE WITH THE FOLLOWING PUBLICATIONS OF THE AMERICAN CONCRETE INSTITUTE, ACI: THE "BUILDING CODE REQUIREMENTS OF REINFORCED CONCRETE" (ACI 318, LATEST EDITION), THE "SPECIFICATIONS OF STRUCTURAL CONCRETE" (ACI 301, LATEST EDITION), AND THE CONCRETE REPAIR MANUAL.
2. IF THE TROWEL METHOD OF REPAIR IS CHOSEN, PROVIDE POLYMER-MODIFIED PATCH MORTAR PER SPECIFICATIONS.
3. IF THE PUMP OR CAST-IN-PLACE METHODS OF REPAIR IS CHOSEN, PROVIDE CONCRETE PER SPECIFICATIONS.
4. IF THE REPAIR AREA IS POURED USING READY MIX CONCRETE, PROVIDE EUCLID SENTINEL SILVER ANODES AT EACH END AND AT 2'-0" O.C. ON ALL REINFORCING EXPOSED DURING DEMOLITION. DO NOT COAT AREA OF REBAR WITH ANODES WITH BONDING AGENT/PROTECTION
5. REINFORCEMENT: ALL DEFORMED BARS ASTM A615 GRADE 60.
6. ALL REINFORCEMENT SHALL BE SECURELY HELD IN PLACE WHILE PLACING CONCRETE. IF REQUIRED, ADDITIONAL BARS STIRRUPS OR CHAIRS SHALL BE PROVIDED BY THE CONTRACTOR TO FURNISH SUPPORT FOR ALL BARS.

PAINTING

1. PAINT ALL EXPOSED CONCRETE IN AREAS THAT HAVE BEEN PREVIOUSLY PAINTED TO MATCH EXISTING PAINT TYPE AND COLOR. COORDINATE WITH THE OWNER.

THE NOTES ON THIS PAGE ARE FOR CONCRETE REPAIR ONLY. SEE S1 FOR GENERAL AND MATERIAL NOTES.

NOTE: TEMPORARY SHORING IS THE SOLE RESPONSIBILITY OF THE CONTRACTOR. PROVIDE NECESSARY SHORING TO LIMIT DEFLECTION OF EXISTING CONSTRUCTION TO REMAIN TO NO GREATER THEN 1/8" PER 4'-0". PROTECT EXISTING CONSTRUCTION NOT SCHEDULED FOR DEMOLITION (WALLS, CEILINGS, FLOOR DRAINS, ETC.)

NOTE: CONTRACTOR TO FIELD VERIFY CLEARANCES, DIMENSIONS, AND OTHER APPLICABLE FIELD CONDITIONS PRIOR TO COMMENCING WORK. SHOULD DISCREPANCIES BE DISCOVERED, ALERT EOR IMMEDIATELY

CONCRETE REPAIR NOTES ON SECTIONS AND DETAILS:

1. PRIOR TO BEGINNING REPAIR, OUTLINE EXTENT OF PATCH ON CONCRETE SURFACE WITH SPRAY PAINT FOR REVIEW BY EOR.
2. SAWCUT EDGES 3" MINIMUM BEYOND LIMITS OF UNSOUND CONCRETE AREAS TO 1/2" MAXIMUM DEPTH. TAKE EXTREME CARE TO AVOID CUTTING REBAR AND TENDONS. SQUARE CUT CORNERS IN PATTERNS AS SIMPLE AS POSSIBLE.
3. TROWEL APPLY POLYMER-MODIFIED PATCH MORTAR PER SPECIFICATIONS.
4. IF PUMP METHOD OF REPAIR IS CHOSEN, PATCHING CONCRETE PER SPECIFICATIONS.
5. 1" MIN. CLEARANCE BETWEEN EXPOSED REBAR AND SOUND CONCRETE IF REBAR IS EXPOSED DURING REMOVAL OF UNSOUND CONCRETE.
6. PRIOR TO PLACING PATCH MATERIAL, SANDBLAST OR WATERBLAST EXISTING SURFACES AND EXPOSED REINFORCING SURFACES. REINFORCING SHALL BE CLEAN, SOUND, AND FREE OF CONTAMINANTS. COAT CONCRETE AND REINFORCING WITH COMPATIBLE PRIMER AND/OR BONDING AGENT/ REINFORCEMENT PROTECTION SPECIFIED IN NOTES PER MANUFACTURER'S SPECIFICATIONS
7. PROVIDE EUCLID SENTINEL SILVER ANODES AT EACH END AND AT 2'-0" O.C. ON ALL REINFORCING EXPOSED DURING DEMOLITION. DO NOT COAT AREA OF REBAR WITH ANODES WITH BONDING AGENT/PROTECTION. ANODES ARE ONLY USED WITH READY MIX CONCRETE.

BAR SIZE	STEEL REINFORCING LAP SCHEDULE							REBAR REPLACEMENT CHART:	
	CONCRETE LAP SPLICE LENGTHS (IN)						CMU LAP SPLICE(IN)	BAR #	MIN DIA*
	f'c=3000psi		f'c=4000psi		f'c=5000psi				
TOP	OTHER	TOP	OTHER	TOP	OTHER				
3	22	17	20	15	17	13	18	4	15/32"
4	29	22	26	19	23	17	24	5	18/32"
5	36	28	32	24	28	22	30	6	43/64"
6	43	33	38	29	34	26	36	7	25/32"
7	63	48	56	42	49	38	42	8	29/32"
8	72	55	64	48	56	43	48	9	65/64"

* = REPLACE BAR IF DIAMETER IS < THAN THE VALUE LISTED

CONSTRUCTION SOLUTIONS, INC.
961687 GATEWAY BLVD - SUITE 101B
AMELIA ISLAND, FLORIDA 32034
PHONE: (904) 261-8703 FAX: (877) 808-1839
FLORIDA CERTIFICATE OF AUTHORIZATION NO. 26752



REPAIRS AND RENOVATIONS
FOR
BEACHCOMBER I CONDOMINIUMS
JACKSONVILLE BEACH, FLORIDA

STRUCTURAL
NOTES

REV:	DATE:	DESC:

NOT FOR
CONSTRUCTION -
FOR REVIEW -
BID SET

JEFFREY B. SELLERS
FL PE # 68313
3/1/18

DRAWING SHEET:

CR1

BID SET

THIS DRAWING IS THE PROPERTY OF CONSTRUCTION SOLUTIONS, INC. ANY USE OR REPRODUCTION WITHOUT THE EXPRESSED WRITTEN CONSENT OF CONSTRUCTION SOLUTIONS, INC. IS PROHIBITED. ALL RIGHTS OF DESIGN AND INVENTION ARE EXPRESSLY RESERVED.

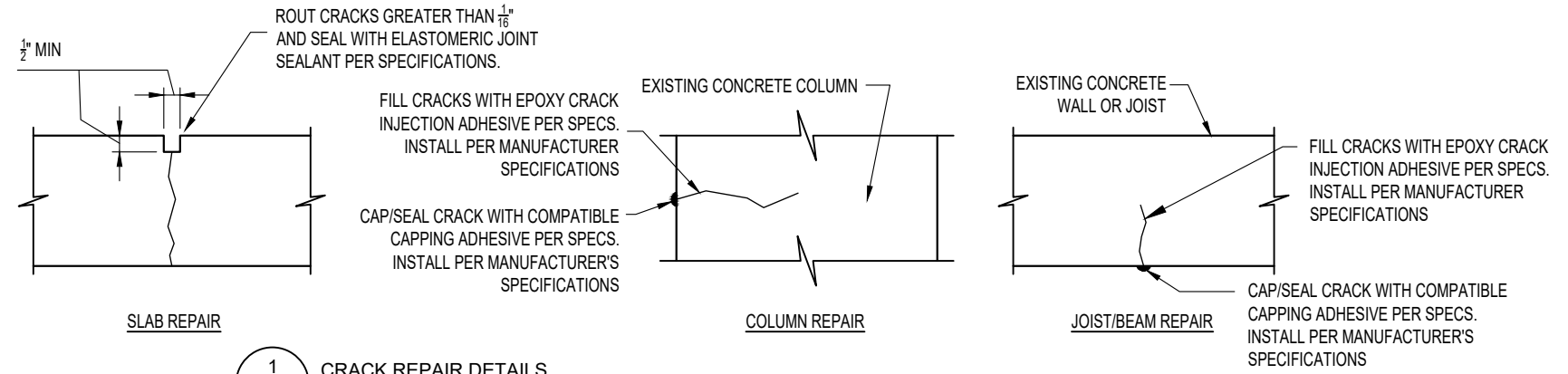

1 CRACK REPAIR DETAILS
CR2 SCALE: NONE

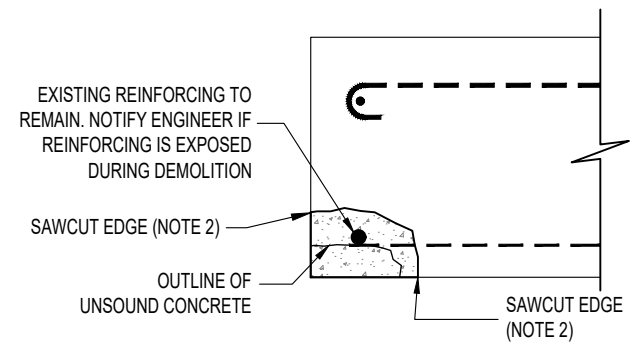

6 PARTIAL DEPTH SLAB EDGE REPAIR DETAIL
CR2 SCALE: NONE

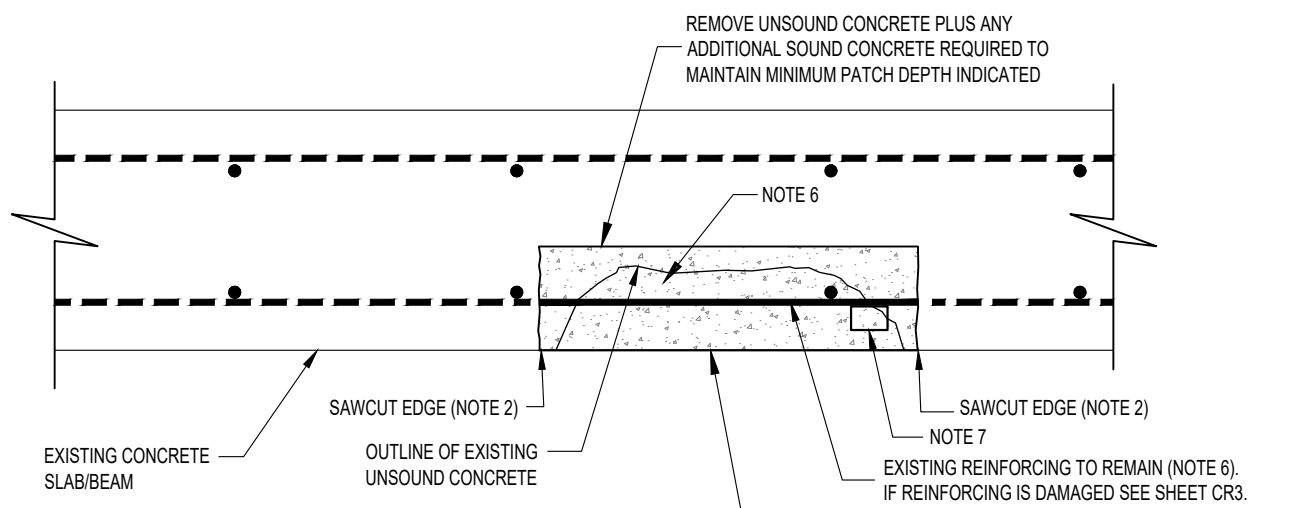

4 TYPICAL PARTIAL DEPTH SLAB BOTTOM REPAIR
CR2 SCALE: NONE

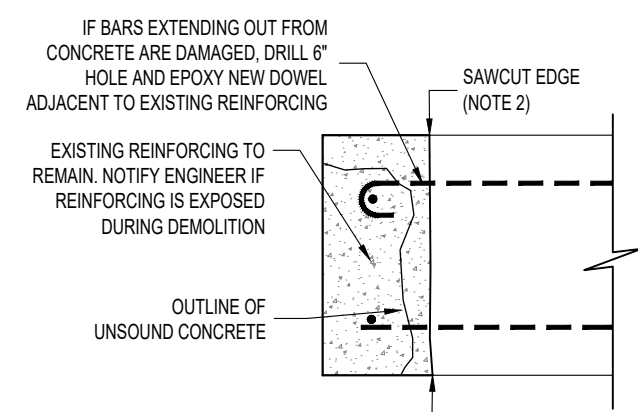

7 FULL DEPTH SLAB EDGE REPAIR DETAIL
CR2 SCALE: NONE

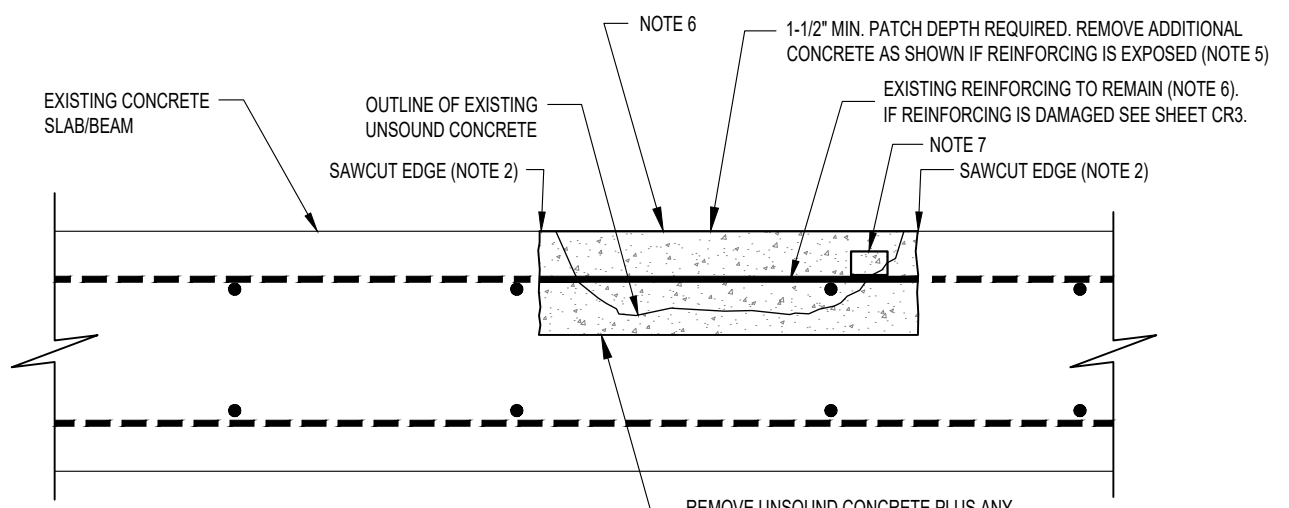

5 TYPICAL PARTIAL DEPTH SLAB TOP REPAIR
CR2 SCALE: NONE

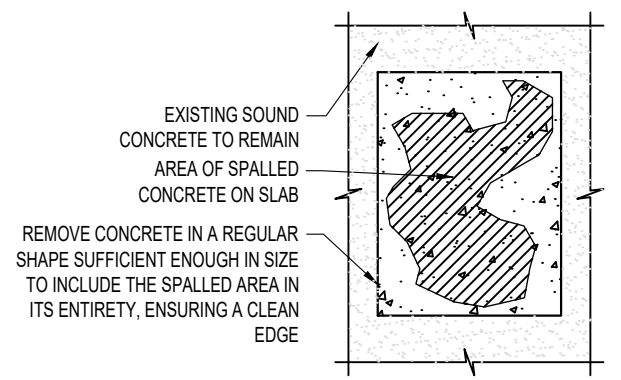

2 SPALL REPAIR PLAN DETAIL
CR2 SCALE: NONE

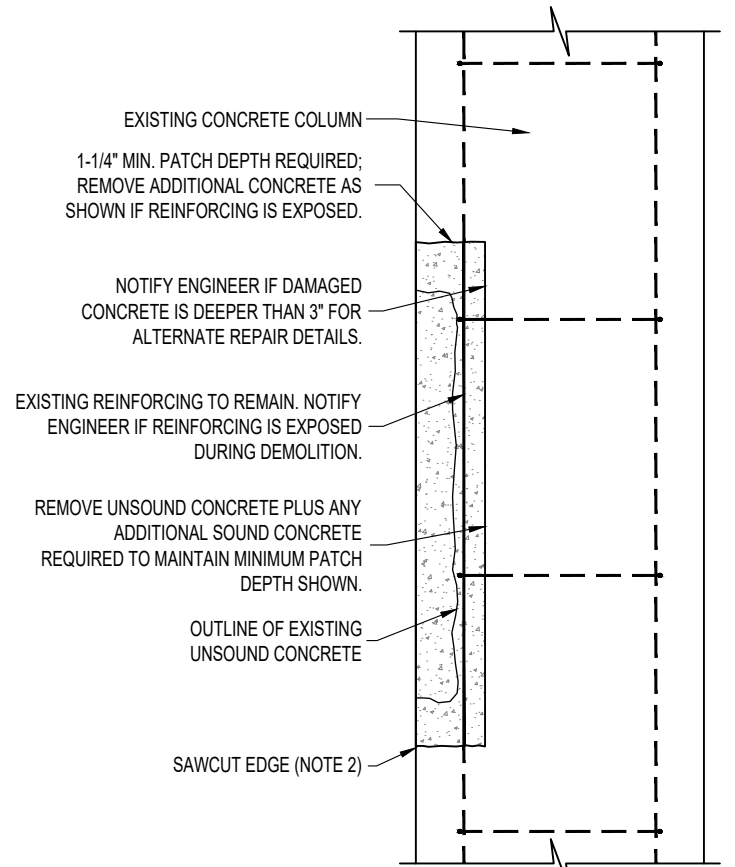

3 TYPICAL PARTIAL DEPTH CONCRETE COLUMN REPAIR DETAIL
CR2 SCALE: NONE

CONSTRUCTION SOLUTIONS, INC.
961687 GATEWAY BLVD - SUITE 101B
AMELIA ISLAND, FLORIDA 32034
PHONE: (904) 261-8703 FAX: (877) 808-1839
FLORIDA CERTIFICATE OF AUTHORIZATION NO. 26752



REPAIRS AND RENOVATIONS
FOR
BEACHCOMBER I CONDOMINIUMS
JACKSONVILLE BEACH, FLORIDA

REPAIR DETAILS

REV:	DATE:	DESC:

NOT FOR CONSTRUCTION - FOR REVIEW - FOR BID SET

JEFFREY B. SELLERS
FL PE # 68313
3/1/18

DRAWING SHEET:
CR2

BID SET

THIS DRAWING IS THE PROPERTY OF CONSTRUCTION SOLUTIONS, INC. ANY USE OR REPRODUCTION WITHOUT THE EXPRESSED WRITTEN CONSENT OF CONSTRUCTION SOLUTIONS, INC. IS PROHIBITED. ALL RIGHTS OF DESIGN AND INVENTION ARE EXPRESSLY RESERVED.

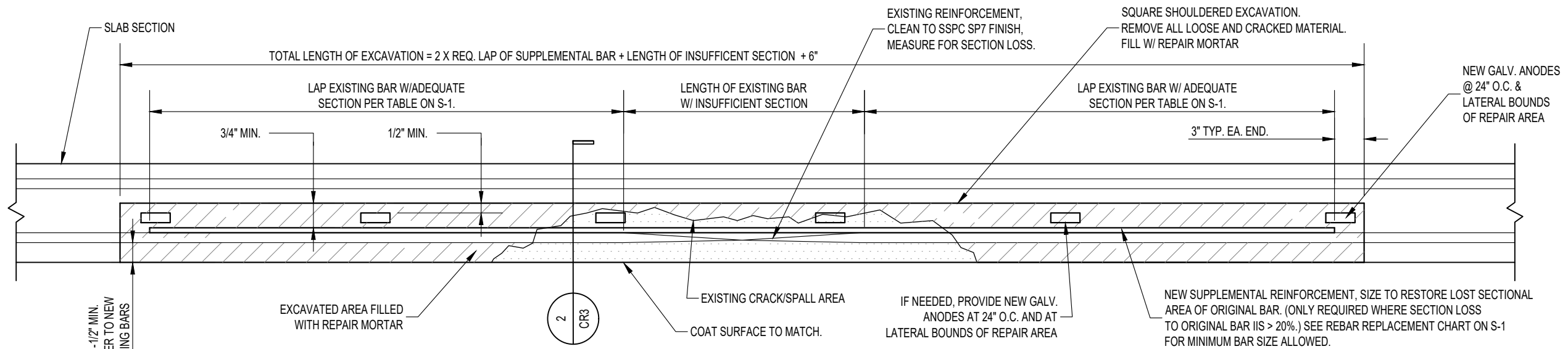

1
CR3
SLAB LONGITUDINAL SECTION
SUPPLEMENTAL REBAR
SCALE: NONE
BOTTOM REINFORCING IS SHOWN SPLICED IN THIS DETAIL.
TOP REINFORCING MAY BE SPICED SIMILARLY.

CONCRETE REPAIRS AND ANODE INSTALLATION SHALL BE COMPLETED IN ACCORDANCE WITH SPECIFICATION SECTION 030130.71 WHICH WILL BE SUPPLIED UPON REQUEST. ANODES ARE TO BE USED ONLY WITH PUMPED READY MIX CONCRETE.

NOTE: IF SUPPLEMENTARY REINFORCEMENT IS NOT REQUIRED, EXCAVATED AREA SHALL EXTEND 3-INCHES BEYOND SOUND REBAR WITH FULL SECTION AND NO INDICATIONS OF CORROSION.

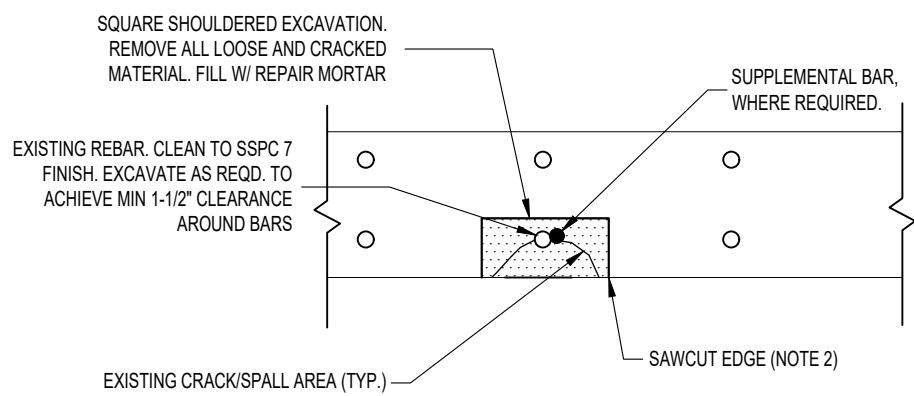

2
CR3
TYPICAL SLAB CROSS SECTION
SCALE: NONE

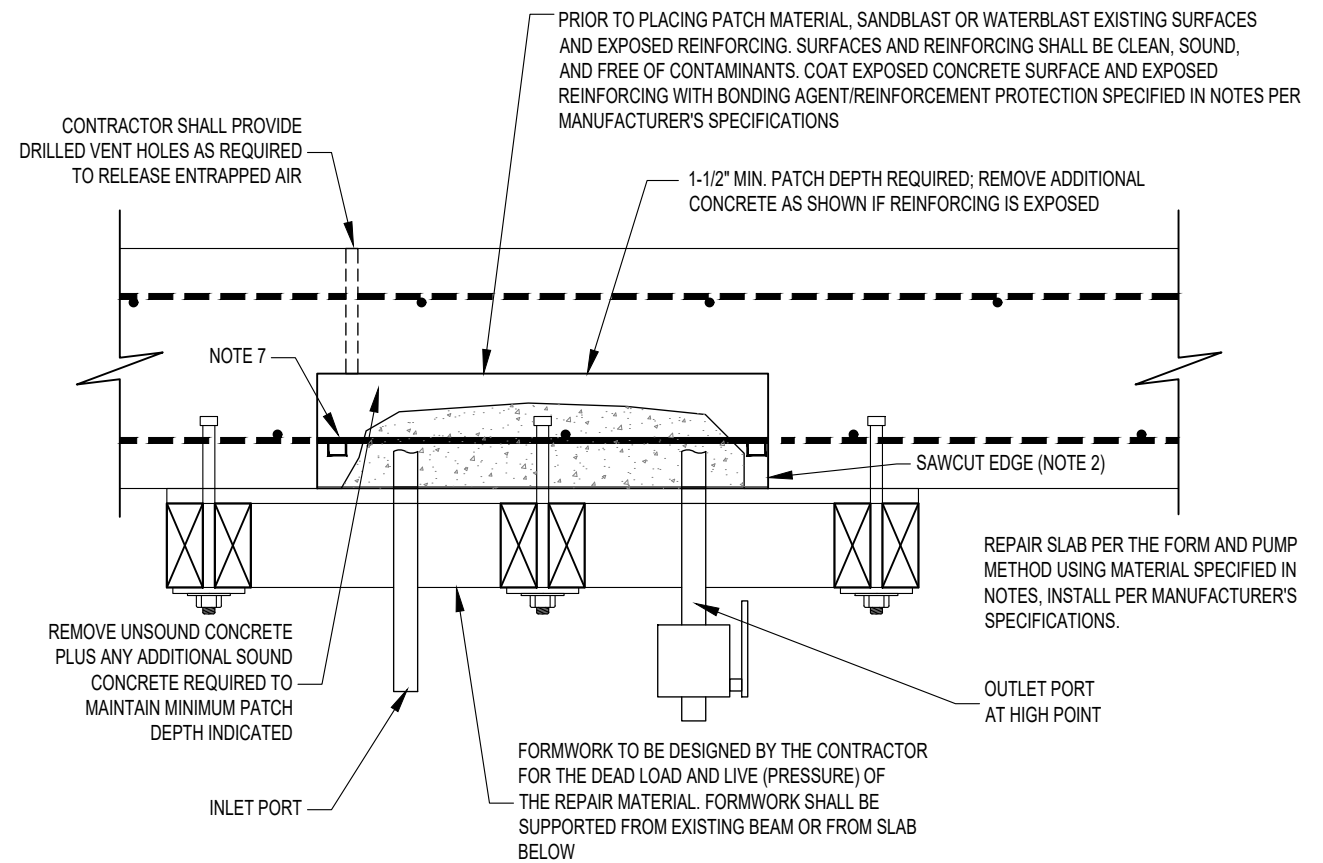

3
CR3
TYPICAL PARTIAL DEPTH CONCRETE JOIST/BEAM
REPAIR: PUMP FROM BOTTOM METHOD
SCALE: NONE

CONSTRUCTION SOLUTIONS, INC.
961687 GATEWAY BLVD - SUITE 101B
AMELIA ISLAND, FLORIDA 32034
PHONE: (904) 261-8703 FAX: (877) 808-1839
FLORIDA CERTIFICATE OF AUTHORIZATION NO. 26752



REPAIRS AND RENOVATIONS
FOR
BEACHCOMBER I CONDOMINIUMS
JACKSONVILLE BEACH, FLORIDA

REPAIR DETAILS

REV.	DATE	DESC.

NOT FOR CONSTRUCTION - FOR REVIEW - BID SET
JEFFREY B. SELLERS
FL PE # 68313
3/1/18

DRAWING SHEET:
CR3

BID SET

THIS DRAWING IS THE PROPERTY OF CONSTRUCTION SOLUTIONS, INC. ANY USE OR REPRODUCTION WITHOUT THE EXPRESSED WRITTEN CONSENT OF CONSTRUCTION SOLUTIONS, INC. IS PROHIBITED. ALL RIGHTS OF DESIGN AND INVENTION ARE EXPRESSLY RESERVED.

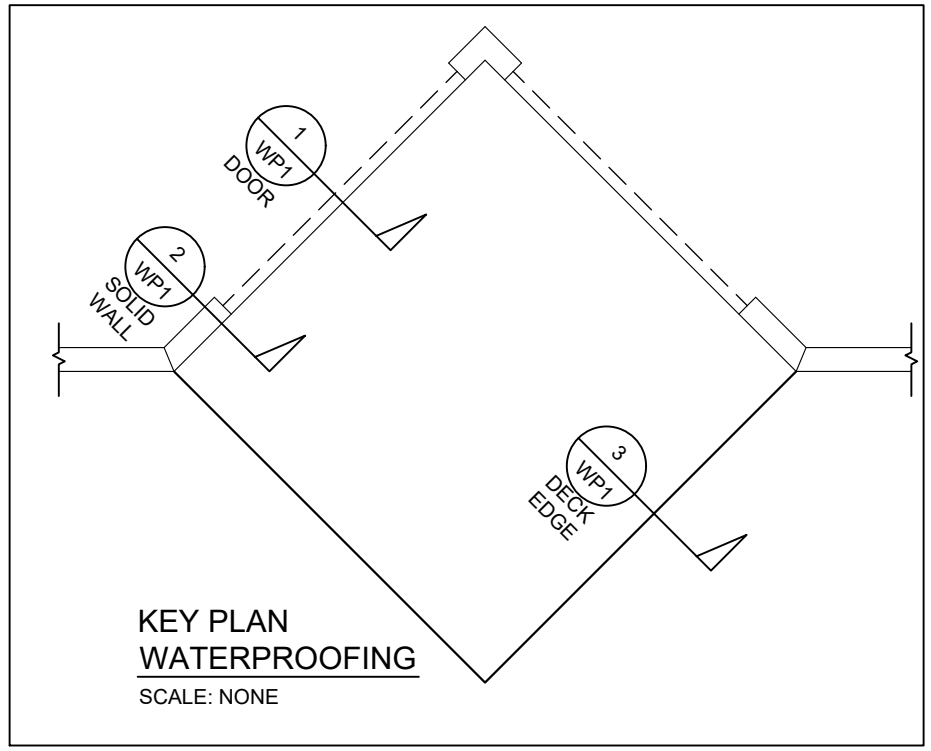

NEW 4"x4"x032 KYNAR COATED ALUMINUM FLASHING, CONTINUOUS. WET SET IN FULL BED OF TREMCO DYMONIC FC SEALANT AND DETAIL LEADING EDGE W/ CANT BEAD. ATTACH WITH 6D RINGSHANK ROOFING NAILS AT 16" O.C.

EXISTING SLIDING DOOR TO BE REMOVED AND REPLACED OR RESET IN SILL PAN. SILL PAN SHALL BE SET IN FULL BED OF SEALANT.

AFTER NEW DECK COATING IS IN PLACE, PROVIDE BEAD OF SEALANT COMPATIBLE WITH COATING UNDER EDGE OF EXISTING SLIDING DOOR OR SILL PAN.

NEW DECK AND COATING PER SHEET WP2

NEW TILE PER SHEET WP2

NEW MASTERSEAL 1500 WATERPROOFING MEMBRANE, EXTEND BELOW AND ABOVE NEW FLASHING UP VERT. FACE OF BEAM AND BELOW HORIZ. LEG. TWO SEPARATE APPLICATIONS REQUIRED BEFORE AND AFTER NEW FLASHING INSTALLATION. **NOTE: TOP COAT REQUIRED WHERE HIGH TRAFFIC AND EXPOSURE TO ULTRAVIOLET LIGHT IS OF CONCERN.

NEW CEMENT BOARD SHEATHING, SEE WP2

NEW TILE SEE WP2

NEW FLOOR SHEATHING SEE GENERAL NOTES

NEW FLOOR FRAMING SEE PLAN

NEW FLOOR SHEATHING SEE GENERAL NOTES

NEW FLOOR FRAMING SEE PLAN

NEW FASCIA BOARD. MUST HANG A MIN $\frac{3}{4}$ " BELOW FINISHED BOTTOM OF BEAM

CANT BEAD OF SEALANT

4 WATERPROOFING DETAIL - DECK AT EXISTING DOOR
WP1 SCALE: NONE

5 WATERPROOFING DETAIL - DECK EDGE
WP1 SCALE: NONE

CONSTRUCTION SOLUTIONS, INC.
37 GATEWAY BLVD - SUITE 101B
A ISLAND, FLORIDA 32034
E: (904) 261-8703 FAX: (877) 808-1839
3A CERTIFICATE OF AUTHORIZATION NO. 26752

REPAIRS AND RENOVATIONS
FOR
BEACHCOMBER I CONDOMINIUMS
JACKSONVILLE BEACH, FLORIDA

WATERPROOFING
DETAILS

REV:	DATE:	DESC:

NOT FOR
CONSTRUCTION -
FOR REVIEW
BID SET

JEFFREY B. SELLERS
FL PE # 68313
3/1/18

DRAWING SHEET:
WP1

BID SET

THIS DRAWING IS THE PROPERTY OF CONSTRUCTION SOLUTIONS, INC. ANY USE OR REPRODUCTION WITHOUT THE EXPRESSED WRITTEN CONSENT OF CONSTRUCTION SOLUTIONS, INC. IS PROHIBITED. ALL RIGHTS OF DESIGN AND INVENTION ARE EXPRESSLY RESERVED.

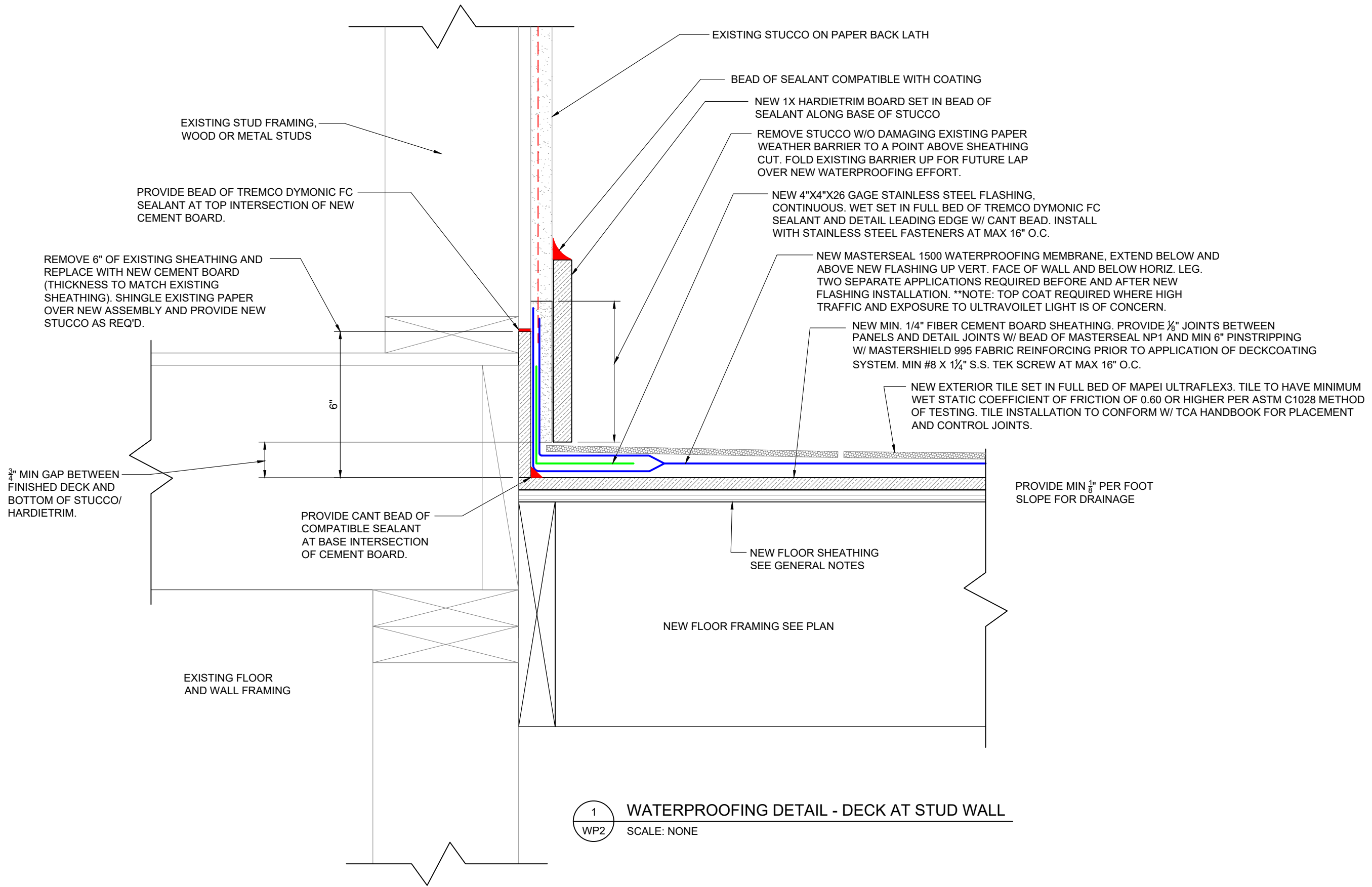

1 WATERPROOFING DETAIL - DECK AT STUD WALL
 WP2 SCALE: NONE

CONSTRUCTION SOLUTIONS, INC.
 37 GATEWAY BLVD - SUITE 101B
 A ISLAND, FLORIDA 32034
 P: (904) 261-8703 FAX: (877) 808-1839
 CA CERTIFICATE OF AUTHORIZATION NO. 26752



REPAIRS AND RENOVATIONS
 FOR
 BEACHCOMBER I CONDOMINIUMS
 JACKSONVILLE BEACH, FLORIDA

WATERPROOFING
 DETAILS

REV.	DATE:	DESC:

NOT FOR
 CONSTRUCTION -
 FOR REVIEW
 BID SET

JEFFREY B. SELLERS
 FL PE # 68313
 3/1/18

DRAWING SHEET:
WP2

BID SET